

**SINGER**  
**253-211**

Form 20946

1157

Printed in U. S. A.

# LIST OF PARTS



# SINGER<sup>SM</sup>

MACHINE No. 253-211

THE SINGER MANUFACTURING COMPANY

SM A Trademark of THE SINGER MANUFACTURING COMPANY

From the library of: Diamond Needle Corp

## INSTRUCTIONS FOR OILING

Before starting the machine, fill the oil reservoir in the base to the HIGH MARK with TYPE A or TYPE C OIL, sold by Singer Sewing Machine Company, as instructed in Form 20748

TYPE C OIL is to be used, when an oil is desired which will produce a minimum of stain on fabrics, even after a long period of storage.

The reservoir holds approximately 1-1/2 pints.

When in operation, the oil level in the reservoir should be frequently inspected to keep it from going below the LOW MARK in the reservoir. Refill to HIGH MARK with TYPE A or TYPE C OIL.

## INDEX

	Page
Accessories.....	26
Belt Guard (Hinged).....	26
Face Plate Thread Lubricator .....	28
Fittings .....	21
Foot Lifter Parts .....	27
Knee Lifter Parts.....	27
Machine No. 253-211.....	7
Numerical List of Parts.....	29
Thread Unwinder (For Four Spools).....	28

From the library of Diamond Needle Corp

## INSTRUCTIONS FOR ORDERING

In ordering from this list, use ONLY the part NUMBER in the FIRST column.

The number stamped on a Sewing Machine Part is in every case the number of the single part only.

Every combination of parts sent out as such has its specific number, which, although not stamped on the parts, must be used when ordering the combination.

Each number always indicates the SAME PART in whatever list it appears, or for whatever machine.

The letters after some of the numbers indicate the style of finish only, as follows:

- A--Hardened, Polished, Nickel Plated and Buffed
- B--Polished, Nickel Plated and Buffed
- C--Hardened Only
- D--Polished Only
- E--Soft, Not Polished
- F--Hardened and Polished
- G--Bright Rumbled and Nickel Plated
- H--Blued
- J--Nickel Plated Only
- K--Hardened and Nickel Plated
- L--Brass Plated
- M--Oxidized
- R--Phosphate Coating Formed on Surface of Iron or Steel
- S--Cadmium Plated
- T--Copper Plated
- U--Zinc Plated
- V--Silver Plated
- W--Polished and Nickel Plated
- X--Black Oxide for Iron and Steel
- Y--Black Nickel Plated Only
- Z--Chromium Plated
- A.A--Buffed and Chromium Plated
- A.B--Hardened, Polished, Buffed and Chromium Plated
- A.E--Hardened, Bright Rumbled and Nickel Plated
- A.F--Hardened, Bright Rumbled, Nickel Plated, Bright Rumbled and Chromium Plated
- A.G--Alumilite (Plain)
- A.H--Alumilite (Dyed) Color Must be Stated
- A.J--Polished, Nickel Plated and Chromium Plated
- A.K--Hardened, Polished, Nickel Plated and Chromium Plated
- A.L--Heat Treated for Toughness
- A.L.D--Heat Treated for Toughness and Polished
- A.L.X--Heat Treated for Toughness and Black Oxide

## INSTRUCTIONS FOR ORDERING

- A.S--Black Moulded Phenolic
- A.T--Beige Moulded Phenolic
- A.U--Brown Moulded Phenolic
- A.W--Hardened then Flame Coated with Tungsten Carbide
- B.A--Chrome Nickel Satin Finish
- B.B--Hardened and Chrome Nickel, Satin Finished
- C.R--Hardened and Phosphate Coating Formed on Surface of Steel
- F.J--Hardened, Polished and Nickel Plated
- T.A--Hardened, Polished, Copper and Nickel Plated and Buffed
- T.B--Copper and Nickel Plated and Polished
- T.J--Copper and Nickel Plated Only
- T.K--Hardened, Copper and Nickel Plated
- T.L--Copper and Brass Plated
- T.M--Copper Plated and Oxidized
- X.C--Hardened and Black Oxide for Iron and Steel
- Z.A--Hardened, Polished Nickel Plated, Buffed and Chromium Plated
- Z.B--Polished, Nickel Plated, Buffed and Chromium Plated
- Z.C--Hardened and Chromium Plated
- Z.D--Polished and Chromium Plated
- Z.G--Bright Rumbled, Nickel Plated, Bright Rumbled and Chromium Plated
- Z.J--Nickel and Chromium Plated
- Z.T--Copper and Chromium Plated

These letters MUST BE USED when they appear in the list; and AFTER the number as in the list.

In this series:

1 to 1500, 50001 to 51500 and 140001 to 142,000 are screw numbers  
1501 to 1800 and 51500 to 51800 are nut numbers  
1801 to 2000 and 51801 to 52000 are roller numbers  
2001 to 50000 and 52001 to 140000 and 142001 to 190000 are Sewing Machine Parts, 190001 and upward are numbers of Electrical Parts.

The figures in the second column refer only to the plates, illustrating the parts, and are NOT TO BE USED in ordering.

Parts marked with an asterisk (\*) are furnished only when repairs are made at the factory.

When ordering parts which differ as to gauge (the distance between seams), the gauge as well as the number must be given on the order.

LIST OF PARTS COMPLETE  
FOR

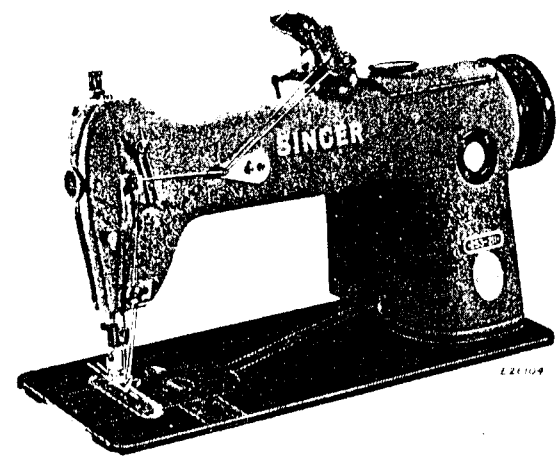

MACHINE No. 253-211

For Sewing Medium Weight Fabrics. Two Needles,  
Two Loopers. Length of Stitches 6 to 22 to the inch.  
Gauges 3/32 in. to 1/2 in. in Steps of 1/32 in. Needle Bar  
Stroke 1 3/16 in.

SINGER Needles should be used  
in SINGER Machines  
These Needles and their Containers  
are marked with the  
Company's Trademark "SIMANCO" 1

Needles in Containers marked  
"FOR SINGER MACHINES"  
are NOT SINGER made needles 2

No.	Plate	Name
*146863	-----	Arm.....
		NOTE: When ordering No. 146863 state color required.
16552	25037	Arm Dowel Pin (2).....
146552	25037	Arm Screw (front) (2).....
146551	25037	Arm Screw Stud (back) (2).....
146651	25093	Arm Shaft (horizontal) with 1036AL, 140542AL and 140552AL.....
146670	-----	Arm Shaft (horizontal) 146651 with 146581.
146864	25093	Arm Shaft (horizontal) Bevel Gear, right hand spiral with 140333AL and two 1259AL.....
140333AL	25093	Arm Shaft (horizontal) Bevel Gear Position Screw.....
1259AL	25093	Arm Shaft (horizontal) Bevel Gear Set Screw (2).....
143008	25093	Arm Shaft (horizontal) Bushing (center)...
140296AL	25093	Arm Shaft (horizontal) Bushing (center) Set Screw.....
147112	25093	Arm Shaft (horizontal) Flanged Bushing (back).....

From the library of: Diamond Needle Corp

No.	Plate	Name
146790	25093	Arm Shaft (horizontal) Flanged Bushing (back) Oil Sump Tube with Holder.....
207E	25093	Arm Shaft (horizontal) Flanged Bushing (back) Oil Sump Tube Holder Screw.....
140296AL	25093	Arm Shaft (horizontal) Flanged Bushing (back) Set Screw.....
146672	25093	Arm Shaft (horizontal) Flanged Bushing (front).....
140331AL	25093	Arm Shaft (horizontal) Flanged Bushing (front) Set Screw.....
144D	25093	Arm Shaft (horizontal) Screw (back).....
140359E	25093	Arm Shaft (horizontal) Screw Plug (front)
143236	25093	Arm Shaft (horizontal) Screw Plug (front) Washer (fiber).....
146661	25093	Arm Shaft (upright).....
143015	25093	Arm Shaft (upright) Bevel Gear (lower) left hand spiral with two 1259AL.....
1259AL	25093	Arm Shaft (upright) Bevel Gear (lower) Set Screw (2).....
143015	25093	Arm Shaft (upright) Bevel Gear (upper) left hand spiral, with two 1259AL.....
1259AL	25093	Arm Shaft (upright) Bevel Gear (upper) Set Screw (2).....
146505	25093	Arm Shaft (upright) Bushing (lower).....
140298AL	25093	Arm Shaft (upright) Bushing (lower) Set Screw.....
147111	25093	Arm Shaft (upright) Bushing (upper).....
140298AL	25093	Arm Shaft (upright) Bushing (upper) Set Screw.....
146867	25074	Arm Top Cover.....
	NOTE:	When ordering No. 146867, state color required.
146868	25074	Arm Top Cover and Stitch Regulator Cap
	NOTE:	When ordering No. 146868, state color required.
146869	25074	Arm Top Cover and Stitch Regulator Cap complete, Nos. 335X, 146868, 146870 and 146871.....
146870	25074	Arm Top Cover and Stitch Regulator Cap Gasket.....
146871	25074	Arm Top Cover and Stitch Regulator Cap Latch.....
335X	25074	Arm Top Cover and Stitch Regulator Cap Latch Screw.....
146508	25074	Arm Top Cover Gasket.....
51369R	25074	Arm Top Cover Screw (4).....
146872	25094	Attachment Slide.....
146873	25094	Attachment Slide complete, Nos. 51282X, 146872 and 146874.....
146874	25094	Attachment Slide Spring.....
51282X	25094	Attachment Slide Spring Screw.....
*146876	-----	Bed with 146570 and two each 126150 and 140734E.....
	NOTE:	Due to the accuracy required for gear alignment, Bed cannot be supplied separately and can only be sent out as a unit, Arm and Bed assembled.

No.	Plate	Name
143024	25093	Bed Hole Plug.....
146514	25037	Bed Leg (back).....
965E	25037	Bed Leg (back) Screw (2).....
146877	25037	Bed Leg (front, long).....
146516	25073	Bed Rotary Shaft.....
146650	-----	Bed Rotary Shaft 146516 with 146558.....
146517	25073	Bed Rotary Shaft Bevel Gear, right hand spiral with two 1259AL.....
1259AL	25073	Bed Rotary Shaft Bevel Gear, Set Screw (2).....
146518	25073	Bed Rotary Shaft Bushing (back).....
50554AL	25073	Bed Rotary Shaft Bushing (back) Set Screw
146519	25073	Bed Rotary Shaft Bushing (front).....
50554AL	25073	Bed Rotary Shaft Bushing (front) Set Screw
146520	25073	Bed Rotary Shaft Bushing (intermediate) ..
448AL	25073	Bed Rotary Shaft Bushing (intermediate) Set Screw.....
64342	25073	Bed Rotary Shaft Collar with 454AL.....
454AL	25073	Bed Rotary Shaft Collar Set Screw.....
146521	25041	Bed Slide (left).....
4307	25041	Bed Slide (left) Spring.....
725X	25041	Bed Slide (left) Spring Screw (2).....
146522	25041	Bed Slide (left) complete, Nos. 4307, 146521 and two 725X.....
146006	25094	Bed Slide (right, button type) for 146007..
146523	25100	Bed Slide (right, button type) for 146526..
146834	25102	Bed Slide (right, button type) for 146835..
146848	-----	Bed Slide (right, button type) for 146846..
146849	25105	Bed Slide (right, button type) for 146847..
146061	25094	Bed Slide (right, latch type) for 146062... ..
146687	-----	Bed Slide (right, latch type) for 146692... ..
146722	-----	Bed Slide (right, latch type) for 146723... ..
146820	-----	Bed Slide (right, latch type) for 146821... ..
146827	-----	Bed Slide (right, latch type) for 146828... ..
146007	25094	Bed Slide (right, button type) complete for Throat Plates with no off-set, Nos. 1423X, 146006, 146524, 146525 and two 240C.....
146526	25100	Bed Slide (right, button type) complete, for Throat Plates with 3/64 in. off-set, Nos. 1423X, 146523, 146524, 146525 and two 240C.....
146835	25102	Bed Slide (right, button type) complete for Throat Plates with 3/32 in. off-set, Nos. 1423X, 146524, 146525, 146834 and two 240C.....
146846	-----	Bed Slide (right, button type) complete for Throat Plates with 9/64 in. off-set, Nos. 1423X, 146524, 146525, 146848 and two 240C.....
146847	25105	Bed Slide (right, button type) complete for Throat Plates with 3/16 in. off-set, Nos. 1423X, 146524, 146525, 146849 and two 240C.....

No.	Plate	Name
146062	25094	Bed Slide (right, latch type) complete for Throat Plates with no off-set, Nos. 146061, 146688, 146689, 146690, 146691 and four 1470X.
146692	-----	Bed Slide (right, latch type) complete for Throat Plates with 3/64 in. off set, Nos. 146687, 146688, 146689, 146690, 146691 and four 1470X.
146828	-----	Bed Slide (right, latch type) complete for Throat Plates with 3/32 in. off-set, Nos. 146688, 146689, 146690, 146691, 146827 and four 1470X.
146723	-----	Bed Slide (right, latch type) complete for Throat Plates with 9/64 in. off-set, Nos. 146688, 146689, 146690, 146691, 146722 and four 1470X.
146821	-----	Bed Slide (right, latch type) complete for Throat Plates with 3/16 in. off-set, Nos. 146688, 146689, 146690, 146691, 146820 and four 1470X.
146525	25100	Bed Slide (right) Knob.
146688	25094	Bed Slide (right) Latch.
146689	25094	Bed Slide (right) Latch Guide.
1470X	25094	Bed Slide (right) Latch Guide Screw (2).
146690	25094	Bed Slide (right) Latch Spring.
146691	25094	Bed Slide (right) Spring.
146524	25094	Bed Slide (right) Spring.
1423X	25094	Bed Slide (right) Spring Screw.
1470X	25094	Bed Slide (right) Spring Screw (2).
240C	25094	Bed Slide (right) Spring Stop Screw (2).
146913	-----	Combination of Feed and Stitch Regulator Parts, Nos. 143015, 146547, 146545, 146864, 146883 and 146914.
146528	25041	Face Plate
	NOTE:	When ordering No. 146528, state color required.
146529	25041	Face Plate Gasket.
140061J	25041	Face Plate Screw (lower) (3).
140050J	25041	Face Plate Screw (upper).
146879	25072	Feed Bar.
146880	-----	Feed Bar 146879 with 1607X and 140695X.
146949	-----	Feed Bar 146880 with 146935.
147022	25072	Feed Bar Carrier with two each 158E and 176E.
158E	25072	Feed Bar Carrier Clamping Screw (2).
147023	25072	Feed Bar Carrier Hinge Pin.
176E	25072	Feed Bar Carrier Hinge Pin Clamping Screw (2).
143031	25072	Feed Bar Carrier Oil Wick.
143032	25072	Feed Bar Carrier Oil Wick Holder.
147024	-----	Feed Bar Carrier Oil Wick Holder 143032 with 143031.
228E	25072	Feed Bar Carrier Oil Wick Holder Screw (2).

No.	Plate	Name
146934	25072	Feed Bar Slide Block.
146681	25072	Feed Bar Slide Block Oil Wick.
146529	25072	Feed Bar Slide Block Oil Wick Holder.
146882	-----	Feed Bar Slide Block Oil Wick Holder 146539 with 146881.
50579J	25072	Feed Bar Slide Block Oil Wick Holder Screw.
		<b>Feed Dog (See Fittings Pages 21 to 27)</b>
157J	25100	Feed Dog Screw.
140695X	25072	Feed Dog Stop Screw.
1607X	25072	Feed Dog Stop Screw Nut.
51061AL	25093	Feed Eccentric Body Set Screw (3).
7071	25093	Feed Eccentric Clamping Washer (2).
217J	25093	Feed Eccentric Clamping Washer Screw (2).
146883	25093	Feed Eccentric (adjustable) complete, Nos. 50328C, two each 217J, 7071 and three 51061AL.
146914	25093	Feed Lifting Eccentric with three 440AL.
440AL	25093	Feed Lifting Eccentric Set Screw (3).
146885	25072	Feed Lifting Rock Shaft.
143052	25072	Feed Lifting Rock Shaft and Feed Rock Shaft Oil Wick Holder.
228E	25072	Feed Lifting Rock Shaft and Feed Rock Shaft Oil Wick Holder Screw.
147042	25072	Feed Lifting Rock Shaft Bushing (back).
146933	25072	Feed Lifting Rock Shaft Bushing (front).
447AL	25072	Feed Lifting Rock Shaft Bushing Set Screw (2).
143039	25072	Feed Lifting Rock Shaft Cap.
223E	25072	Feed Lifting Rock Shaft Cap Screw (2).
147029	25072	Feed Lifting Rock Shaft Collar with two 460AL (2).
460AL	25072	Feed Lifting Rock Shaft Collar Set Screw (4).
146537	25093	Feed Lifting Rock Shaft Connecting Rod.
146887	25093	Feed Lifting Rock Shaft Connecting Rod Hinge Pin.
462AL	25072	Feed Lifting Rock Shaft Connecting Rod Hinge Pin Set Screw.
146888	25072	Feed Lifting Rock Shaft Crank (back) with 462AL and two 50083AL.
50083AL	25072	Feed Lifting Rock Shaft Crank (back) Clamping Screw (2).
146889	25072	Feed Lifting Rock Shaft Crank (front) with 157X.
146935	-----	Feed Lifting Rock Shaft Crank (front) 146889 with 146934.
157X	25072	Feed Lifting Rock Shaft Crank (front) Clamping Screw.
146945	25072	Feed Lifting Rock Shaft Hole Plug.
140359E	25072	Feed Lifting Rock Shaft Oil Plug Screw.
143236	25072	Feed Lifting Rock Shaft Oil Plug Screw Washer (fiber).
146891	25072	Feed Lifting Rock Shaft Oil Wick.

From the Board of Directors

No.	Plate	Name
146892	25072	Feed Lifting Rock Shaft Oil Wick (long) . . .
147037	25072	Feed Lifting Rock Shaft Oil Wick (short) (2) . . . . .
147047	25072	Feed Lifting Rock Shaft Oil Wick Clamping Plate . . . . .
197E	25072	Feed Lifting Rock Shaft Oil Wick Clamping Plate Screw . . . . .
50328C	25093	Feed Regulating Screw . . . . .
146893	25072	Feed Rock Shaft . . . . .
146894	-----	Feed Rock Shaft Nos. 197E, 140359E, 143236, 146891, 146893, 146896, 147047 and two 147045 . . . . .
147042	25072	Feed Rock Shaft Bushing (back) . . . . .
147043	25072	Feed Rock Shaft Bushing (front) . . . . .
447AL	25072	Feed Rock Shaft Bushing Set Screw (2) . . .
143048	25072	Feed Rock Shaft Cap . . . . .
223E	25072	Feed Rock Shaft Cap Screw (2) . . . . .
147029	25072	Feed Rock Shaft Collar with two 460AL . . .
460AL	25072	Feed Rock Shaft Collar Set Screw (2) . . . .
146545	25093	Feed Rock Shaft Connecting Rod . . . . .
146887	25093	Feed Rock Shaft Connecting Rod Hinge Pin
462AL	25072	Feed Rock Shaft Connecting Rod Hinge Pin Set Screw . . . . .
146895	25072	Feed Rock Shaft Crank with 462AL and two 157X . . . . .
157X	25072	Feed Rock Shaft Crank Clamping Screw (2) . . . . .
140359E	25072	Feed Rock Shaft Oil Plug Screw . . . . .
143236	25072	Feed Rock Shaft Oil Plug Screw Washer (fiber) . . . . .
146891	25072	Feed Rock Shaft Oil Wick . . . . .
146896	25072	Feed Rock Shaft Oil Wick (long) . . . . .
147045	25072	Feed Rock Shaft Oil Wick (short) (2) . . . .
147047	25072	Feed Rock Shaft Oil Wick Clamping Plate .
197E	25072	Feed Rock Shaft Oil Wick Clamping Plate Screw . . . . .
146548	25095	Looper (back) closed eye . . . . .
	NOTE:	When ordering No. 146548, state gauge required.
1253AL	25095	Looper (back) Set Screw . . . . .
146549	25095	Looper (front) closed eye . . . . .
	NOTE:	When ordering No. 146549, state gauge required.
1253AL	25095	Looper (front) Set Screw . . . . .
146550	25073	Looper Avoiding Eccentric with two 1259AL
146553	25073	Looper Avoiding Eccentric Connection (forked) with two 896AL . . . . .
896AL	25073	Looper Avoiding Eccentric Connection Clamping Screw (2) . . . . .
1259AL	25073	Looper Avoiding Eccentric Set Screw (2) .
146554	25073	Looper Avoiding Eccentric Slide Block . . .
146556	25073	Looper Ball Crank . . . . .
146897	25095	Looper Ball Crank Arm with 51320AL . . . .
146923	25095	Looper Ball Crank Arm 146897 with 1520J, 128551 and 146919 . . . . .

No.	Plate	Name
51320AL	25095	Looper Ball Crank Arm Clamping Screw . .
132790	25073	Looper Ball Crank Connection Ball Sleeve (two pieces) . . . . .
164232	25073	Looper Ball Crank Connection Ball Sleeve Guide . . . . .
146557	25073	Looper Ball Crank Connection Nos. two each 896AL, 51715AL, 131927 and 131928 . . . . .
146558	-----	Looper Ball Crank Connection 146557 with 132790, 146556 and 164232 . . . . .
896AL	25073	Looper Ball Crank Connection Cap (lower) Screw (2) . . . . .
131927	25073	Looper Ball Crank Connection Cap (upper) Screw Stud (2) . . . . .
51715AL	25073	Looper Ball Crank Connection Cap (upper) Screw Stud Nut (2) . . . . .
131928	25073	Looper Ball Crank Connection Cap (upper) Screw Stud Nut Lock Washer (2) . . . . .
146559	25073	Looper Ball Crank Hinge Pin . . . . .
448AL	25073	Looper Ball Crank Hinge Pin Set Screw (2) . . . . .
146948	25095	Looper Ball Crank Pitman Ball Screw Stud (right) . . . . .
1520J	25095	Looper Ball Crank Pitman Ball Screw Stud (right) Nut . . . . .
128551	25095	Looper Ball Crank Pitman Ball Screw Stud (right) Nut Locking Plate . . . . .
146730	25095	Looper Ball Crank Pitman End Bearing (left) Body with two 175AL . . . . .
175AL	25095	Looper Ball Crank Pitman End Bearing (left) Cap Screw (2) . . . . .
1664J	25095	Looper Ball Crank Pitman End Bearing (left) Nut . . . . .
146918	25095	Looper Ball Crank Pitman End Bearing (right) Body with two 175AL . . . . .
175AL	25095	Looper Ball Crank Pitman End Bearing (right) Cap Screw (2) . . . . .
146919	-----	Looper Ball Crank Pitman End Bearing (right) 146918 with 146948 . . . . .
146936	25095	Looper Ball Crank Pitman Rod . . . . .
146937	25095	Looper Ball Crank Pitman Rod 146936 with 51769C . . . . .
146938	25095	Looper Ball Crank Pitman Rod with Throw- out Device complete, Nos. 29043, 50169J, 146732, 146733, 146754, 146904, 146937 and two 51159J . . . . .
51769C	25095	Looper Ball Crank Pitman Rod Nut . . . . .
146947	25095	Looper Ball Crank Pitman Rod Oil Shield .
51460E	25095	Looper Ball Crank Pitman Rod Oil Shield Screw . . . . .
7071	25095	Looper Ball Crank Pitman Rod Oil Shield Screw Washer . . . . .
146565	25095	Looper Holder with 896AL and two 1253AL
146739	25095	Looper Holder 146565 with 1664J, 146567 and 146730 . . . . .



No.	Plate	Name
146567	25095	Looper Holder Bushing (eccentric) with 146647.....
146647	25095	Looper Holder Bushing Pin.....
896AL	25095	Looper Holder Clamping Screw.....
146568	25073	Looper Holder Hinge Pin.....
146569	25073	Looper Holder Rock Shaft with 140439E....
*146570	-----	Looper Holder Rock Shaft Bracket.....
	NOTE:	Due to the accuracy required for Looper Rock Shaft alignment, Looper Holder Rock Shaft Bracket cannot be supplied separately and can only be sent out as a unit Arm, Bed and Looper Holder Rock Shaft Bracket assembled.
143126	-----	Looper Holder Rock Shaft Bracket Oil Pipe Clamping Sleeve Adaptor.....
231E	-----	Looper Holder Rock Shaft Bracket Oil Plug Screw (2).....
140734E	25037	Looper Holder Rock Shaft Bracket Screw (2).....
126150	-----	Looper Holder Rock Shaft Bracket Screw Washer (2).....
146571	25073	Looper Holder Rock Shaft Bushing (back)...
448AL	25073	Looper Holder Rock Shaft Bushing (back) Set Screw.....
146572	25073	Looper Holder Rock Shaft Bushing (front)...
448AL	25073	Looper Holder Rock Shaft Bushing (front) Set Screw.....
140439E	25073	Looper Holder Rock Shaft Oil Plug Screw...
146732	25095	Looper Throw-out Releaser.....
146733	25095	Looper Throw-out Releaser Cap.....
51159J	25095	Looper Throw-out Releaser Cap Screw (2).....
146754	25095	Looper Throw-out Sleeve.....
146904	25095	Looper Throw-out Spring.....
50169J	25095	Looper Throw-out Spring Screw.....
29043	25095	Looper Throw-out Spring Screw Washer...
146924	-----	Looper Throw-cut Device and Pitman Rod complete, Nos. 1520J, 128551, 146919 and 146938.....
146512	25074	Machine Pulley (disc, power) "V" belt groove (outside diameter of belt groove 2.9 in.) with two 51283A1.....
51283AL	25074	Machine Pulley Set Screw (2).....
146573	25096	Needle Bar (hollow).....
146574	-----	Needle Bar complete, for 3/32 in. to 1/2 in. gauges, Nos. 146573 and 146587.
	NOTE:	When ordering No. 146574, state gauge required.
146907	25096	Needle Bar Bushing (lower).....
1133E	25096	Needle Bar Bushing (lower) Set Screw....
146804	25096	Needle Bar Bushing (lower and upper) Oil Wick.....
146805	25096	Needle Bar Bushing (lower and upper) Oil Wick complete, Nos. 146703, 146804 and two 146580.....

No.	Plate	Name
146703	25096	Needle Bar Bushing (lower and upper) Oil Wick Clamp and Retainer.....
146580	25096	Needle Bar Bushing (lower and upper) Oil Wick Clip (2).....
146576	25096	Needle Bar Bushing (upper).....
140440J	25096	Needle Bar Bushing (upper) Oil Plug Screw.....
1133E	25096	Needle Bar Bushing (upper) Set Screw....
146959	25096	Needle Bar Connecting Link.....
146581	-----	Needle Bar Connecting Link 146959 with 146582.....
146582	25093	Needle Bar Connecting Link Hinge Stud...
140552AL	25093	Needle Bar Connecting Link Hinge Stud Clamping Screw.....
1036AL	25093	Needle Bar Connecting Link Hinge Stud Position Set Screw.....
175E	25096	Needle Bar Connecting Stud Clamping Screw.....
139110	25096	Needle Bar Connecting Stud Oil Pad (wick).....
139111	25096	Needle Bar Connecting Stud Slide Block...
146908	25096	Needle Bar Connecting Stud Slide Block Guide.....
SS329E	25096	Needle Bar Connecting Stud Slide Block Guide Screw (2).....
140542AL	25093	Needle Bar Crank Position Screw.....
146665	25047	Needle Bar Thread Retainer (lower).....
146666	25047	Needle Bar Thread Retainer (upper).....
146585	25047	Needle Bar Thread Retainer Bracket.....
146586	25047	Needle Bar Thread Retainer Bracket complete, Nos. 10107, 140546C, 146585, 146665, 146666 and two each 42483, 50163XC and 54865.....
402J	25047	Needle Bar Thread Retainer Bracket Screw.....
42483	25047	Needle Bar Thread Retainer Disc (2)....
140546C	25047	Needle Bar Thread Retainer Disc Screw..
50163XC	25047	Needle Bar Thread Retainer Screw (2)...
54865	25047	Needle Bar Thread Retainer Screw Washer (2).....
10107	25047	Needle Bar Thread Retainer Spring.....
146587	25096	Needle Clamp with two 1498F, for 3/32 in. to 1/2 in. gauges in steps of 1/32 in. ..
	NOTE:	When ordering No. 146587, state gauge required.
		Needle Guard (See Fittings Pages 21 to 27)
146742	25094	Needle Guard Holder.....
146743	25094	Needle Guard Holder Bracket.....
190J	25094	Needle Guard Holder Bracket Screw.....
190J	25094	Needle Guard Holder Screw.....
176J	25100	Needle Guard Screw.....
1498F	25096	Needle Set Screw (2).....
146591	25046	Oil Flow Body.....
143061	25046	Oil Flow Body Gasket (2).....

Home Library  
 Digitized by eGangotri

No.	Plate	Name
143062	25046	Oil Flow Window.....
143063	25046	Oil Flow Window Cap.....
50257X	25046	Oil Flow Window Cap Screw (4).....
143370	25046	Oil Lead.....
51369E	25046	Oil Lead Screw.....
146593	25046	Oil Pipe for 146597.....
146594	25010	Oil Pipe with two each 143124 and 143125 for oiling Bed Rotary Shaft Intermediate Bearing.....
146595	25010	Oil Pipe with two each 143124 and 143125 for oiling Looper Rock Shaft Hinge Pin..
146596	25010	Oil Pipe with two each 143124 and 143125 for oiling Thread (under) Take-up Shaft Front Bearing.....
143065	25046	Oil Pipe Clamping Sleeve for 146597.....
143066	25046	Oil Pipe Clamping Sleeve Nut.....
146597	25046	Oil Pipe complete, from Oil Pump to Arm Shaft (horizontal) Center Bearing, Nos. 146593 with 143065 and 143066 (for Agents only).....
143124	25010	Oil Pipe Clamping Sleeve (6).....
143126	25046	Oil Pipe Clamping Sleeve Adaptor for 146660 (3).....
143126	-----	Oil Pipe Clamping Sleeve Adaptor (fastened to Bed) (2).....
143125	25010	Oil Pipe Clamping Sleeve Nut (6).....
146659	25046	Oil Pump Centrifugal Body.....
146660	-----	Oil Pump Centrifugal Body 146659 with three 143126.....
143071	25046	Oil Pump Centrifugal Body Position Pin (2)
157E	25046	Oil Pump Centrifugal Body Screw (3)....
146600	25046	Oil Pump Centrifugal Cover.....
143073	25046	Oil Pump Centrifugal Impeller.....
50123E	25093	Oil Pump Centrifugal Impeller Locking Screw.....
146657	25046	Oil Pump Centrifugal Screen.....
146658	25046	Oil Pump Centrifugal Screen Frame.....
189E	25046	Oil Pump Centrifugal Screen Frame Screw (3).....
146744	25037	Oil Removing Wick (head end).....
146745	25037	Oil Removing (head end) Holder Body....
146746	-----	Oil Removing Wick (head end) Holder Body 146745 with 146698 and 146744 (for Agents only).....
140553E	25037	Oil Removing Wick (head end) Holder Body Hinge Screw.....
146698	25037	Oil Removing Wick (head end) Holder Body Spring.....
146700	25037	Oil Removing Wick (head end) Holder Body Stop and Spring Clip.....
228E	25037	Oil Removing Wick (head end) Holder Body Stop and Spring Clip Screw.....
146747	25037	Oil Removing Wick (head end) Holder Body complete, Nos. 228E, 140553E, 146696, 146697, 146698, 146700, 146744 and 146745.....

No.	Plate	Name
146696	25037	Oil Removing Wick (head end) Holder Hinge Plate and Cover.....
146697	25037	Oil Removing Wick (head end) Holder Hinge Plate and Cover Gasket.....
1364X	25037	Oil Removing Wick (head end) Holder Hinge Plate and Cover Screw (3).....
146604	25073	Oil Wick for oiling Looper Ball Crank Pitman End Bearing (left).....
146605	25073	Oil Wick Holder.....
193E	25073	Oil Wick Holder Tube Bracket Screw....
146606	25073	Oil Wick Position Bracket with 140239AL.
140239AL	25073	Oil Wick Position Bracket Screw.....
139462	25096	Presser Bar.....
146751	25096	Presser Bar Bushing (lower).....
1133E	25096	Presser Bar Bushing (lower) Set Screw..
146694	25096	Presser Bar Guide Bracket with 1057AL.
1057AL	25096	Presser Bar Guide Bracket Clamping Screw.....
146676	25097	Presser Bar Guide Bracket Lifter.....
807X	25097	Presser Bar Guide Bracket Lifter Hinge Stud.....
146791	25097	Presser Bar Lifting Lever.....
NOTE:		When ordering No. 146791, state color required.
146609	25097	Presser Bar Lifting Lever Extension....
161X	25097	Presser Bar Lifting Lever Extension Screw (2).....
802X	25097	Presser Bar Lifting Lever Hinge Screw..
146610	25097	Presser Bar Lifting Lever Spring.....
146611	25096	Presser Bar Spring.....
146612	25096	Presser Bar Spring Guide Pin.....
146752	25096	Presser Bar Stop with 190J.....
190J	25096	Presser Bar Stop Clamping Screw..... Presser Foot (hinged) Complete (See Fittings Pages 21 to 27)
190J	25096	Presser Foot Screw.....
140441W	25096	Pressure Regulating Thumb Screw.....
51614W	25096	Pressure Regulating Thumb Screw Nut...
146617	25050	Slack Thread Controller.....
54242	25050	Slack Thread Controller Clamp.....
176J	25050	Slack Thread Controller Clamp Screw....
140239AL	25050	Slack Thread Controller Position Screw..
2102	25098	Tension (looper thread) Disc (4).....
51570C	25098	Tension (looper thread) Regulating Thumb Nut (2).....
146792	25099	Tension (looper thread) Releaser (2)....
146794	25099	Tension (looper thread) Releaser Slide...
146620	25099	Tension (looper thread) Releaser Slide Connecting Link.....
110C	25099	Tension (looper thread) Releaser Slide Connecting Link Hinge Screw.....
72C	25099	Tension (looper thread) Releaser Slide Hinge Screw (2).....
217J	25099	Tension (looper thread) Releaser Screw (2).....

No.	Plate	Name
146801	25099	Tension (looper thread) Releaser Nos. 110C, 146620, 146794, 146796, 146797 and two each 72C, 217J, 146792 and 146795.
140442C	25098	Tension (looper thread) Screw Stud (2)
146618	-----	Tension (looper thread) Screw Stud 140442C with 51570C (2)
131740	25098	Tension (looper thread) Spring (2)
59537	25098	Tension (looper thread) Spring Bushing (large) (2)
59538	25098	Tension (looper thread) Spring Bushing (small) (2)
146619	25098	Tension (looper thread) Thread Guard
131696	25098	Tension (looper thread) Thread Guide (2)
68002	25097	Tension (needle thread) Bracket
140443J	25097	Tension (needle thread) Bracket Screw
2102	25097	Tension (needle thread) Disc (4)
51570C	25097	Tension (needle thread) Regulating Thumb Nut (2)
32572	25097	Tension (needle thread) Releasing Disc (2)
54988	25097	Tension (needle thread) Releasing Pin (2)
68003	25097	Tension (needle thread) Releasing Shaft
54872	25097	Tension (needle thread) Releasing Shaft Crank with 624AL
146620	25097	Tension (needle thread) Releasing Shaft Crank Connecting Link
110C	25097	Tension (needle thread) Releasing Shaft Crank Connecting Link Hinge Screw
624AL	25097	Tension (needle thread) Releasing Shaft Crank Set Screw
68261	25097	Tension (needle thread) Releasing Shaft Spring
316C	25097	Tension (needle thread) Releasing Shaft Stop Screw
1547J	25097	Tension (needle thread) Releasing Shaft Stop Screw Nut
50326C	25097	Tension (needle thread) Screw Stud (2)
59539	-----	Tension (needle thread) Screw Stud 50326C with 51570C (2)
225X	25077	Tension (needle thread) Screw Stud Hole Plug
131741	25097	Tension (needle thread) Spring (2)
59537	25097	Tension (needle thread) Spring Bushing (large) (2)
59538	25097	Tension (needle thread) Spring Bushing (small) (2)
131696	25097	Tension (needle thread) Thread Guide (2)
146621	25073	Thread (looper) Take-up with 465AL
1029J	25073	Thread (looper) Take-up Screw
146622	25073	Thread (looper) Take-up Screw Washer (fiber)
465AL	25073	Thread (looper) Take-up Set Screw
146623	25047	Thread (looper) Take-up Stripper
146624	25047	Thread (looper) Take-up Stripper Holder with 906AL

No.	Plate	Name
146625	25047	Thread (looper) Take-up Stripper Plate
146603	-----	Thread (looper) Take-up Stripper Plate 146625 with 237J, 139148, 146623, 146624, 146626, 146628 and two 190J
237J	25047	Thread (looper) Take-up Stripper Plate Screw
146626	25047	Thread (looper) Take-up Stripper Plate Support Plate (2)
	NOTE:	One No. 146626 is screwed onto Machine Bed.
190X	25047	Thread (looper) Take-up Stripper Plate Support Plate Screw (4)
906AL	25047	Thread (looper) Take-up Stripper Set Screw
139148	25047	Thread (looper) Take-up Stripper Staple
190J	25047	Thread (looper) Take-up Stripper Staple Screw (2)
146627	25047	Thread (looper) Take-up Thread Guide (left)
237J	25047	Thread (looper) Take-up Thread Guide (left) Screw
146628	25047	Thread (looper) Take-up Thread Guide (right)
237J	25047	Thread (looper) Take-up Thread Guide (right) Screw
146631	25098	Thread (looper) Thread Tube
1628X	25098	Thread (looper) Thread Tube Screw Stud Nut
146671	25098	Thread (looper) Thread Tube Screw Stud Nut Washer
146632	25098	Thread (looper) Thread Tube Thread Guide
50027J	25098	Thread (looper) Thread Tube Thread Guide Screw
146795	25099	Thread (looper) Uncurler (2)
146796	25099	Thread (looper) Uncurler Plate (Back)
146797	25099	Thread (looper) Uncurler Plate (Front)
146633	25050	Thread (needle) Eyelet (side of arm)
176J	25050	Thread (needle) Eyelet (side of arm) Position Screw
7071	25050	Thread (needle) Eyelet (side of arm) Position Screw Washer
724J	25050	Thread (needle) Eyelet (side of arm) Screw
146634	25096	Thread (needle) Take-up with 51460E
51460E	25096	Thread (needle) Take-up Clamping Screw
54095	25096	Thread (needle) Take-up Plate
68164	25096	Thread (needle) Take-up Plate Spring
1449J	25096	Thread (needle) Take-up Plate Spring Screw
146635	25096	Thread (needle) Take-up complete, Nos. 1449J, 54095, 68164 and 146634
139158	25050	Thread (needle) Thread Guide (2)
146629	25050	Thread (needle) Thread Guide Bracket

No.	Plate	Name
146630	25050	Thread (needle) Thread Guide Bracket Support.....
	NOTE:	When ordering No. 146630, state color required.
217J	25050	Thread (needle) Thread Guide Bracket Support Screw (lower) .....
237J	25050	Thread (needle) Thread Guide Bracket Support Screw (upper) .....
229J	25050	Thread (needle) Thread Guide Screw (4) .. Throat Plate (See Fittings Pages 21 to 27)
691F	25100	Throat Plate Screw (2).....

**SINGER Needles should be used  
in SINGER Machines  
These Needles and their Containers  
are marked with the  
Company's Trademark "SIMANCO" 1**

**Needles in Containers marked  
"FOR SINGER MACHINES"  
are NOT SINGER made needles 2**

No.	Plate	Name
146523	25100	Bed Slide (right) .....
146525	25100	Bed Slide (right) Knob .....
146524	25094	Bed Slide (right) Spring .....
1423X	25094	Bed Slide (right) Spring Screw .....
240C	25094	Bed Slide (right) Spring Stop Screw (2) .....
146526	25100	Bed Slide (right, button-type) complete for Throat Plates with 3/64 in. off-set, Nos. 1423X, 146523, 146524, 146525 and two 240C.....
146802	25100	Feed Dog, 17 teeth (16 teeth to the inch) for 3/32 in. and 1/8 in. gauges, for 146803 .....
	NOTE:	When ordering No. 146802, state gauge required.
146711	25100	Feed Dog with row of teeth between needles, 14 teeth (14 teeth to the inch) for 5/32 in. to 3/8 in. gauges, for 146778 .....
	NOTE:	When ordering No. 146711, state gauge required.
146588	25100	Needle Guard for 3/32 in. to 5/32 in. gauges .....
146644	25100	Needle Guard for 3/16 in. to 9/32 in. gauges.....
146645	25100	Needle Guard for 5/16 in. to 3/8 in. gauges.....
146761	25100	Presser Foot Plate .....
26276	25100	Presser Foot Plate Hinge Pin.....
146712	25100	Presser Foot Shank .....
146762	25100	Presser Foot (hinged) complete for 3/32 in. to 3/8 in. gauges, Nos. 26276, 146712 and 146761 .....
	NOTE:	When ordering No. 146762, state gauge required.
146803	25100	Throat Plate for 3/32 in. and 3/8 in. gauges, for 146802.....
	NOTE:	When ordering No. 146803, state gauge required.
146778	25100	Throat Plate for 5/32 in. to 3/8 in. gauges, for 146711.....
	NOTE:	When ordering No. 146778, state gauge required.

**For Sleeving 3/32" Gauge.**

No.	Plate	Name
146523	25101	Bed Slide (right) .....
146525	25101	Bed Slide (right) Knob.....
146524	25094	Bed Slide (right) Spring .....
1423X	25094	Bed Slide (right) Spring Screw .....
240C	25094	Bed Slide (right) Spring Stop Screw (2).....

From the library of Diamond Needle Corp

No.	Plate	Name
146526	25101	Bed Slide (right, button-type) complete for Throat Plates with 3/64 in. off-set, Nos. 1423X, 146523, 146524, 146525 and two 240C .....
146781	25101	Feed Dog, 19 teeth (14 teeth to the inch) ... NOTE: When ordering No. 146781, state gauge required.
160945	25101	Lap Seam Feller (adjustable) on Shank with 1443J .....
		NOTE: When ordering No. 160945, needle gauge of machine and weight of material must be stated.
1443J	25101	Lap Seam Feller Bracket (adjustable) Screw .....
121449	25101	Lap Seam Feller Clamping Plate .....
1423J	25101	Lap Seam Feller Clamping Plate Screw (2) .....
146588	25101	Needle Guard for 3/32 in. to 5/32 in. gauges .....
146782	25101	Presser Foot Plate .....
		NOTE: When ordering No. 146782, state gauge required.
26276	25101	Presser Foot Plate Hinge Pin .....
146850	25101	Presser Foot Shank .....
139134	25101	Presser Foot Yielding Heel .....
146851	25101	Presser Foot Yielding Heel Connection .....
26276	25101	Presser Foot Yielding Heel Connection Hinge Pin .....
37160	25101	Presser Foot Yielding Heel Connection Spring .....
26276	25101	Presser Foot Yielding Heel Hinge Pin .....
146783	25101	Presser Foot (triple hinged) complete, Nos. 37160, 139134, 146782, 146850, 146851 and three 26276 .....
		NOTE: When ordering No. 146783, state gauge required.
146784	25101	Throat Plate .....
		NOTE: When ordering No. 146784, state gauge required.

For Sleeving Dress Shirts and Straight Run Lap Seam Felling of Light and Medium weight materials, gauges 3 16" to 3 8", in steps of 1/32".

No.	Plate	Name
146834	25102	Bed Slide (right) .....
146525	25102	Bed Slide (right) Knob .....
146524	25094	Bed Slide (right) Spring .....
1423X	25094	Bed Slide (right) Spring Screw .....
240C	25094	Bed Slide (right) Spring Stop Screw (2) ...
146835	25102	Bed Slide (right, button-type) complete, for Throat Plates with 3/32 in. off-set, Nos. 1423X, 146524, 146525, 146834 and two 240C .....

No.	Plate	Name
146856	25102	Feed Dog, 17 teeth (14 teeth to the inch) ... NOTE: When ordering No. 146856, state gauge required.
160945	25102	Lap Seam Feller (adjustable) on Shank with 1443J .....
		NOTE: When ordering No. 160945, needle gauge of machine and weight of material must be stated.
1443J	25102	Lap Seam Feller Bracket (adjusting) Screw .....
121449	25102	Lap Seam Feller Clamping Plate .....
1423J	25102	Lap Seam Feller Clamping Plate Screw (2) .....
146644	25102	Needle Guard for 3/16 in. to 9/32 in. gauges .....
146645	25102	Needle Guard for 5/16 in. to 3/8 in. gauges .....
146862	25102	Presser Foot Plate .....
		NOTE: When ordering No. 146862, state gauge required.
146851	25102	Presser Foot Plate Connection .....
26276	25102	Presser Foot Plate Connection Hinge Pin .....
37160	25102	Presser Foot Plate Connection Spring .....
26276	25102	Presser Foot Plate Hinge Pin .....
146850	25102	Presser Foot Shank .....
146858	25102	Presser Foot Yielding Heel .....
26276	25102	Presser Foot Yielding Heel Hinge Pin .....
146859	25102	Presser Foot (triple hinged) complete, Nos. 37160, 146850, 146851, 146858, 146862 and three 26276 .....
		NOTE: When ordering No. 146859, state gauge required.
146860	25102	Throat Plate .....
		NOTE: When ordering No. 146860, state gauge required.

For Piecing or Goring on Dress Shirts and Straight Run Lap Seam Felling of Light and Medium Weight Materials, 1/8" and 5/32" gauges.

No.	Plate	Name
146523	25103	Bed Slide (right) .....
146525	25103	Bed Slide (right) Knob .....
146524	25094	Bed Slide (right) Spring .....
1423X	25094	Bed Slide (right) Spring Screw .....
240C	25094	Bed Slide (right) Spring Stop Screw (2) ...
146526	25103	Bed Slide (right, button-type) complete, for Throat Plates with 3/64 in. off-set, Nos. 1423X, 146523, 146524, 146525 and two 240C .....
146854	25103	Feed Dog, 17 teeth (14 teeth to the inch) ... NOTE: When ordering No. 146854, state gauge required.
160944	25103	Lap Seam Feller (adjustable) on Shank with 1443J .....
		NOTE: When ordering No. 160944, needle gauges of machine and weight of material must be stated.

From the Library of the National Needle College

## FITTINGS

No.	Plate	Name
1443J	25103	Lap Seam Feller Bracket (adjusting) Screw
121449	25103	Lap Seam Feller Clamping Plate
1423J	25103	Lap Seam Feller Clamping Plate Screw
146588	25103	Needle Guard for 3/32 in. to 5/32 in. gauges
146837	25103	Presser Foot Plate
26276	25103	Presser Foot Plate Hinge Pin
910AL	25103	Presser Foot Plate Hinge Pin Set Screw
1695J	25103	Presser Foot Plate Hinge Pin Set Screw Nut
161088	25103	Presser Foot Shank with 910AL and 1695J
146839	25103	Presser Foot (hinged) complete, Nos. 26276, 146837 and 161088.
		NOTE: When ordering No. 146839, state gauge required.
146855	25103	Throat Plate
		NOTE: When ordering No. 146855, state gauge required.

## For French Lap Seam Felling, 3.8" to 1.2" gauges.

No.	Plate	Name
146523	25104	Bed Slide (right)
146525	25104	Bed Slide (right) Knob
146524	25094	Bed Slide (right) Spring
1423X	25094	Bed Slide (right) Spring Screw
240C	25094	Bed Slide (right) Spring Stop Screw (2)
146526	25104	Bed Slide (right, button-type) complete, for Throat Plates with 5/64 in. off-set, Nos. 1423X, 146523, 146524, 146525 and 240C
161084	25104	Edge Guide with Adjustable Edge Folder on Shank for 1/4 in. to 1/2, needle gauge
		NOTE: When ordering No. 161084, state needle gauge required.
121449	25104	Edge Guide with Adjustable Edge Folder on Shank Clamping Plate
1423J	25104	Edge Guide with Adjustable Edge Folder on Shank Clamping Plate Screw (2)
146841	25104	Feed Dog, 17 teeth (16 teeth to the inch) for 146844
		NOTE: When ordering No. 146841, state gauge required.
146645	25104	Needle Guard for 5/16 in. to 3/8 in. gauges
146845	25104	Needle Guard for 7/16 in. to 1/2 in. gauges
146842	25104	Presser Foot Plate
26276	25104	Presser Foot Plate Hinge Pin
910AL	25104	Presser Foot Plate Hinge Pin Set Screw
1695J	25104	Presser Foot Plate Hinge Pin Set Screw Nut
146838	25104	Presser Foot Shank with 910AL and 1695J

## FITTINGS

No.	Plate	Name
146843	25104	Presser Foot (hinged) complete, Nos. 26276, 146838 and 146842.
		NOTE: When ordering No. 146843, state gauge required.
146844	25104	Throat Plate for 146841
		NOTE: When ordering No. 146844, state gauge required.

## For Sleaving 13/32" to 1/2" gauges.

No.	Plate	Name
146849	25105	Bed Slide (right)
146525	25105	Bed Slide (right) Knob
146524	25094	Bed Slide (right) Spring
1423X	25094	Bed Slide (right) Spring Screw
240C	25094	Bed Slide (right) Spring Stop Screw (2)
146847	25105	Bed Slide (right, button-type) complete, for Throat Plates with 3/16 in. off-set, Nos. 1423X, 146524, 146525, 146849 and two 240C
161100	25105	Feed Dog with row of teeth between needles, 17 teeth (14 teeth to the inch)
		NOTE: When ordering No. 161100, state gauge required.
160945	25105	Lap Seam Feller (adjustable) on Shank with 1443J
		NOTE: When ordering No. 160945, needle gauge of machine and weight of material must be stated.
1443J	25105	Lap Seam Feller Bracket (adjusting) Screw
121449	25105	Lap Seam Feller Clamping Plate
1423J	25105	Lap Seam Feller Clamping Plate Screw (2)
146645	25105	Needle Guard for 5/16 in. to 3/8 in. gauges
146845	25105	Needle Guard for 7/16 in. to 1/2 in. gauges
161095	25105	Presser Foot Plate
		NOTE: When ordering No. 161095, state gauge required.
26276	25105	Presser Foot Plate Hinge Pin
146850	25105	Presser Foot Shank
161096	25105	Presser Foot Yielding Heel
146851	25105	Presser Foot Yielding Heel Connection
26276	25105	Presser Foot Yielding Heel Connection Hinge Pin
37160	25105	Presser Foot Yielding Heel Connection Spring
26276	25105	Presser Foot Yielding Heel Hinge Pin
161097	25105	Presser Foot (triple hinged) complete, Nos. 37160, 146850, 146851, 161095, 161096 and three 26276
		NOTE: When ordering No. 161097, state gauge required.
161101	25105	Throat Plate
		NOTE: When ordering No. 161101, state gauge required.

## ACCESSORIES

No.	Plate	Name
146637	25015	Machine Base and Oil Reservoir.....
146638	25015	Machine Base and Oil Reservoir 146637 with 146639, 146693, 146695 and two 146640 (for Agents only).....
146639	25015	Machine Base and Oil Reservoir Gasket (left).....
146693	25015	Machine Base and Oil Reservoir Oil Return Wick.....
146695	25015	Machine Base and Oil Reservoir Oil Return Wick Position Pad (felt).....
143308	25090	Machine Cushion (felt) (4).....
12361	25090	Machine Hinge Connection (2).....
146640	25015	Machine Pad (felt) (2).....
41400	25090	Machine Rest Pin (wood).....
120344	25090	Oiler with 120345.....
120345	25090	Oiler Spout.....
121741	25090	One Quart Can of Light Grade Stainless Oil Screw Driver.....
120440	25090	Screw Driver.....
121108	25090	Tweezers (curved).....
120341	25090	Wrench.....
8908	25090	Wrench.....
23535	25090	Wrench.....
42850	25090	Wrench.....
146057	25090	Wrench (socket) for 140552AL.....
151281	25090	Wrench (socket).....

## BELT GUARD (Hinged)

No.	Plate	Name
151362	25091	Belt Guard Bottom Section with 2273 and 140321C.....
151363	25091	Belt Guard Top Section with 151366 and two 219R.....
151366	25091	Belt Guard Top Section Fill-in Plate.....
219R	25091	Belt Guard Top Section Fill-in Plate Screw (2).....
151364	25091	Belt Guard Top Section Hinge Pin.....
140321C	25091	Belt Guard Top Section Hinge Pin Set Screw.....
151365	25091	Belt Guard Top Section Lock Spring.....
2273	25091	Belt Guard Top Section Lock Spring Position Pin.....
217E	25091	Belt Guard Top Section Lock Spring Screw.....
151367	25091	Belt Guard (hinged) complete, Nos. 217E, 151362, 151363, 151364, 151365 and two wood Screws 1 1/4 in. No. 12 F.H.B. ...

NOTE: No. 151367 is furnished only when ordered.

## FOOT LIFTER PARTS

No.	Plate	Name
6439	-----	Chain, 36 in. to 45 in., with 56864 and 56865.....
	NOTE:	When ordering No. 6439, state length required.
4879	25030	Chain Connecting Link.....
56864	-----	Chain Hook (large).....
56865	-----	Chain Hook (small).....
126249	25030	Treadle.....
4882	25030	Treadle Shaft.....
126250	25030	Treadle Spring.....
150451	25030	Treadle Stand.....
150452	25030	Treadle complete, Nos. 4879, 4882, 126249, 126250, 150451 and two wood screws 1 in. No. 16 F.H. ....

## KNEE LIFTER PARTS

No.	Plate	Name
146764	25030	Chain length 1-1/4 in., with 46865 and 56865.....
56865	25030	Chain Hook.....
46865	25030	Chain Hook Link.....
146765	25030	Rock Shaft.....
146766	25030	Rock Shaft Hanger with two wood screws 1 in. No. 10 F.H. (2).....
143283	25030	Rock Shaft Knee Arm.....
143285	-----	Rock Shaft Knee Arm complete, Nos. 2767, 143283 and 143284.....
143284	25030	Rock Shaft Knee Arm Hub with 356C and 140351AL.....
140351AL	25030	Rock Shaft Knee Arm Hub Clamping Screw
356C	25030	Rock Shaft Knee Arm Hub Set Screw.....
2767	25030	Rock Shaft Knee Arm Plate with 356C....
356C	25030	Rock Shaft Knee Arm Plate Set Screw....
6337	25030	Rock Shaft Lifting Bracket with two 356C.
7125	25030	Rock Shaft Lifting Bracket Hook.....
356C	25030	Rock Shaft Lifting Bracket Hook Set Screw
356C	25030	Rock Shaft Lifting Bracket Set Screw.....
146768	25030	Rock Shaft Spring.....
1115X	25030	Rock Shaft Spring Screw.....
146769	25030	Rock Shaft Stop Dog (back) with 140351AL
146770	25030	Rock Shaft Stop Dog (front) with 140351AL
140351AL	25030	Rock Shaft Stop Dog Clamping Screw (2)...
146771	25030	Rock Shaft complete, Nos. 1115X, 6337, 7125, 143285, 146765, 146768, 146769, 146770 and two 146766.....
146779	25030	Knee Lifter complete, Nos. 146764 and 146771.....

THREAD UNWINDER  
(For Four Spools)

No.	Plate	Name
151032	25106	Base with 138R and three wood screws 1 in. No. 12 F.H. ....
228764	25106	Spool Pin (4) .....
228766	25106	Spool Rest with 201254C (2) .....
151033	25106	Spool Rest Bracket .....
151034	25106	Spool Rest Bracket Rod .....
138R	25106	Spool Rest Bracket Rod Set Screw .....
51276R	-----	Spool Rest Bracket Screw .....
150203	25106	Spool Rest Cushion (felt) (4) .....
201254C	25106	Spool Rest Set Screw (2) .....
151035	25106	Thread Guide (4) .....
1521R	25106	Thread Guide Nut (8) .....
9525	25106	Thread Guide Nut Washer (8) .....
151037	25106	Thread Unwinder complete, for four spools, Nos. 51276R, 151032, 151033, 151034 two 228766, four each 150203, 151035, 228764 and eight each 1521R and 9525 .....

## FACE PLATE THREAD LUBRICATOR

No.	Plate	Name
146810	25051	Thread Lubricator Adaptor .....
140224J	25051	Thread Lubricator Adaptor Screw .....
7071	25051	Thread Lubricator Adaptor Screw Washer .....
241755	25051	Thread Lubricator Oil Pad (felt) .....
146806	25051	Thread Lubricator Oil Pad Holder .....
146807	-----	Thread Lubricator Oil Pad Holder 146806 with 62827, 240439 and 241755 .....
240439	25051	Thread Lubricator Oil Pad Retainer .....
17822	25051	Thread Lubricator Oil Reservoir Rivet ...
8068	25051	Thread Lubricator Oil Reservoir Rivet Washer (inside) .....
124371	25051	Thread Lubricator Oil Reservoir Rivet Washer (outside) .....
62827	25051	Thread Lubricator Oil Wick .....
146808	-----	Thread Lubricator complete, Nos. 8068, 17822, 124371 and 146807 .....
146809	25051	Thread Lubricator 146808 with 7071, 21202, 50222J, 140224J and 146810 .....
50222J	25051	Thread Lubricator Screw .....
21202	25051	Thread Lubricator Screw Washer .....

No.	Plate	Name
72C	25099	Tension (looper thread) Releaser Slide Hinge Screw for 146801 .....
110C	25099	Tension (looper thread) Releaser Slide Connecting Link Hinge Screw for 146801 .....
110C	25097	Tension (needle thread) Releasing Shaft Crank Connecting Link Hinge Screw .....
138R	25106	Thread Unwinder Spool Rest Bracket Rod Set Screw for 151032 .....
144D	25093	Arm Shaft (horizontal) Screw (back) .....
157J	25100	Feed Dog Screw .....
157X	25072	Feed Lifting Rock Shaft Crank (front) Clamping Screw for 146889 .....
157X	25072	Feed Rock Shaft Crank Clamping Screw for 146895 .....
157E	25046	Oil Pump Centrifugal Body Screw .....
158E	25072	Feed Bar Carrier Clamping Screw for 147022 .....
161X	25097	Presser Bar Lifting Lever Extension Screw .....
175AL	25095	Looper Ball Crank Pitman End Bearing (left) Cap Screw for 146730 .....
175AL	25095	Looper Ball Crank Pitman End Bearing (right) Cap Screw for 146918 .....
175E	25096	Needle Bar Connecting Stud Clamping Screw .....
176E	25072	Feed Bar Carrier Hinge Pin Clamping Screw for 147022 .....
176J	25100	Needle Guard Screw .....
176J	25050	Slack Thread Controller Clamp Screw .....
176J	25050	Thread (needle) Eyelet (side of arm) Position Screw .....
189E	25046	Oil Pump Centrifugal Screen Frame Screw .....
190J	25094	Needle Guard Holder Bracket Screw .....
190J	25094	Needle Guard Holder Screw .....
190J	25096	Presser Bar Stop Clamping Screw for 146752 .....
190J	25096	Presser Foot Screw .....
190X	25047	Thread (looper) Take-up Stripper Plate Support Plate Screw .....
190J	25047	Thread (looper) Take-up Stripper Staple Screw for 146603 .....
193E	25073	Oil Wick Holder Tube Bracket Screw .....
197E	25072	Feed Lifting Rock Shaft Oil Wick Clamping Plate Screw .....
197E	25072	Feed Rock Shaft Oil Wick Clamping Plate Screw for 146894 .....
207E	25093	Arm Shaft (horizontal) Flanged Bushing (back) Oil Sump Tube Holder Screw .....
217E	25091	Belt Guard Top Section Lock Spring Screw for 151567 .....
217J	25093	Feed Eccentric Clamping Washer Screw for 146883 .....
217J	25099	Tension (looper thread) Releaser Screw for 146801 .....



No.	Plate	Name
160944	25103	Lap Seam Feller (adjustable) on Shank with 1443J.....
	NOTE:	When ordering No. 160944, needle gauges of machine and weight of material must be stated.
160945	25101	Lap Seam Feller (adjustable) on Shank with 1443J.....
	NOTE:	When ordering 160945, needle gauge of machine and weight of material must be stated.
161084	25104	Edge Guide with Adjustable Edge Folder on Shank for 1/4 in. to 1/2 in. needle gauge.....
	NOTE:	When ordering No. 161084, state needle gauge required.
161088	25103	Presser Foot Shank with 910AL and 1695J, for 146839.....
161095	25105	Presser Foot Plate for 161097.....
	NOTE:	When ordering No. 161095, state gauge required.
161096	25105	Presser Foot Yielding Heel for 161097.....
161097	25105	Presser Foot (triple hinged) complete, Nos. 37160, 146850, 146851, 161095, 161096 and three 26276.....
	NOTE:	When ordering No. 161097, state gauge required.
161100	25105	Feed Dog with row of teeth between needles, 17 teeth (14 teeth to the inch)..
	NOTE:	When ordering No. 161100, state gauge required.
161101	25105	Throat Plate.....
	NOTE:	When ordering No. 161101, state gauge required.
164232	25073	Looper Ball Crank Connection Ball Sleeve Guide for 146558.....
201254C	25106	Thread Unwinder Spool Rest Set Screw for 228766.....
228764	25106	Thread Unwinder Spool Pin for 151037.....
228766	25106	Thread Unwinder Spool Rest with 201254C for 151037.....
240439	25051	Face Plate Lubricator Oil Pad Retainer for 146807.....
241755	25051	Face Plate Thread Lubricator Oil Pad (felt) for 146807.....

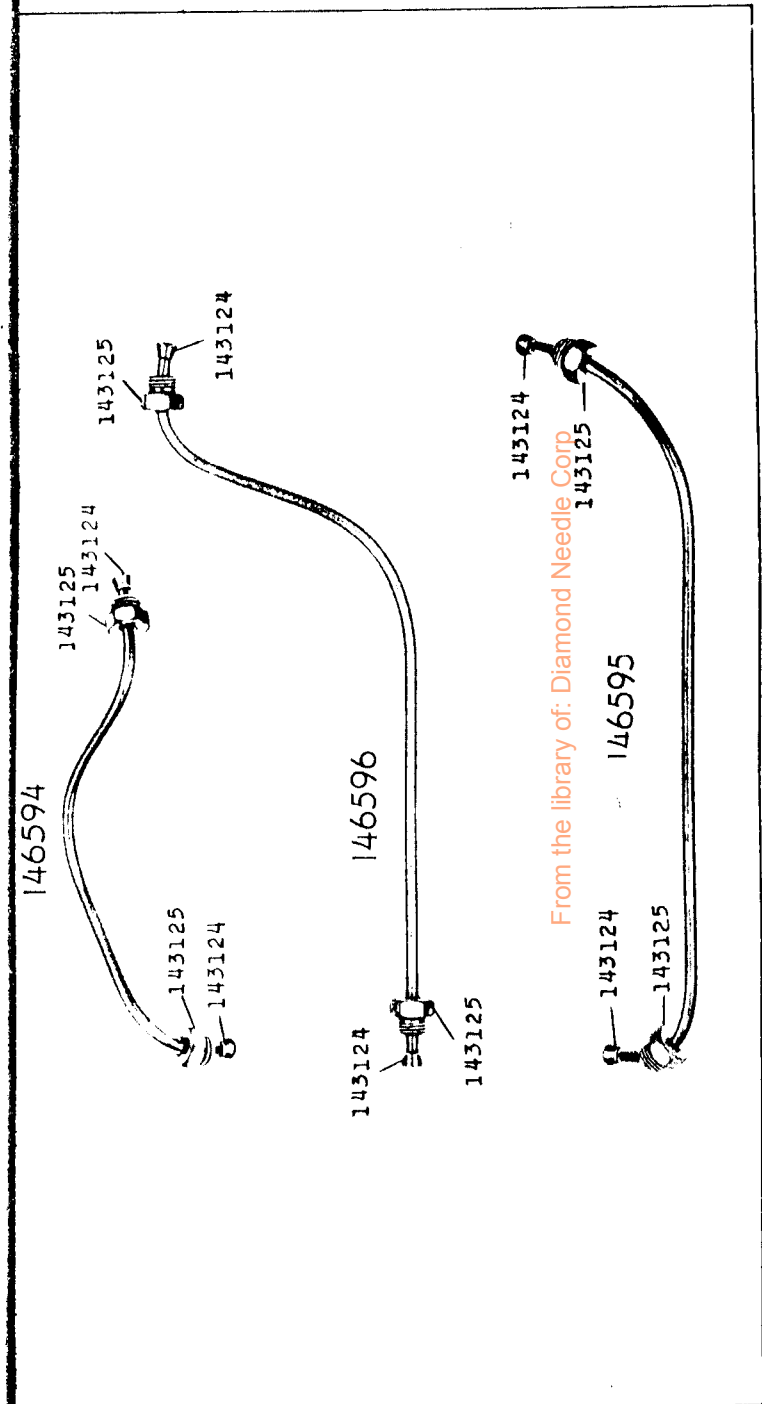

25037-1/2

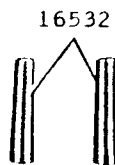
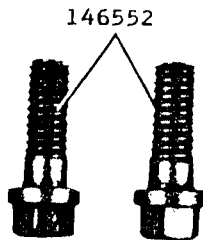
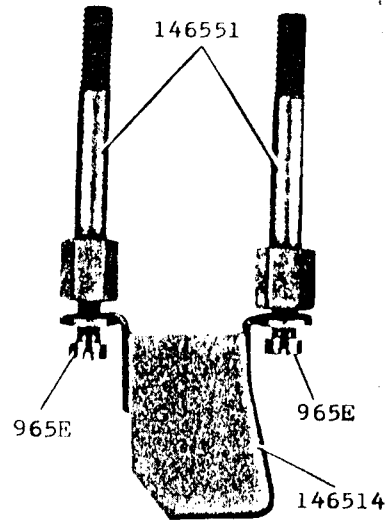
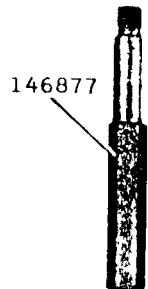
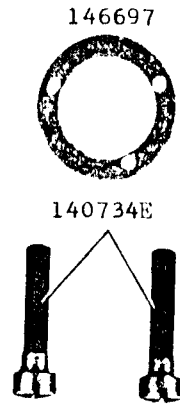
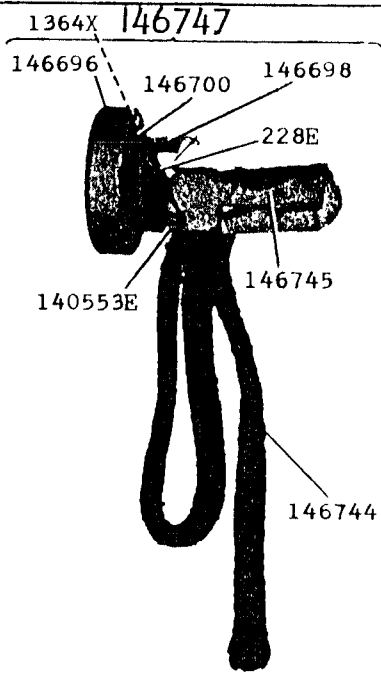

25041-1/2

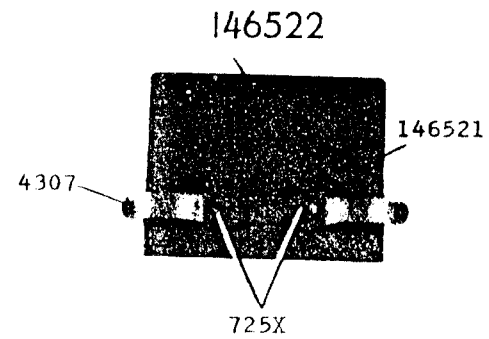
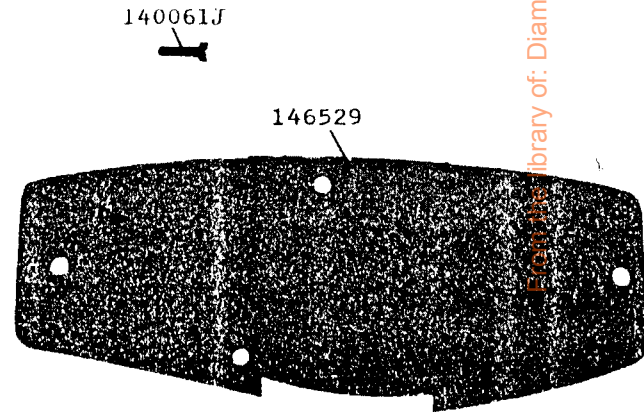
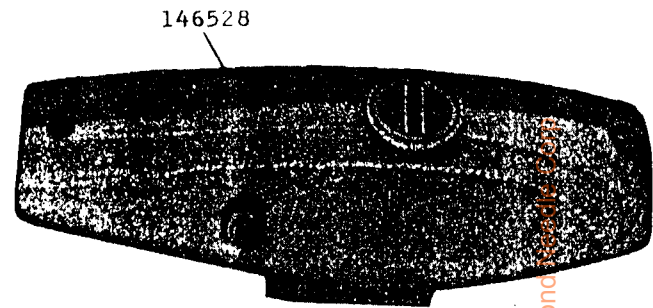
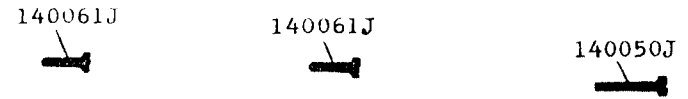

From the library of: Diamond Research Corp.

25046-1/2

25047-2/3

146597

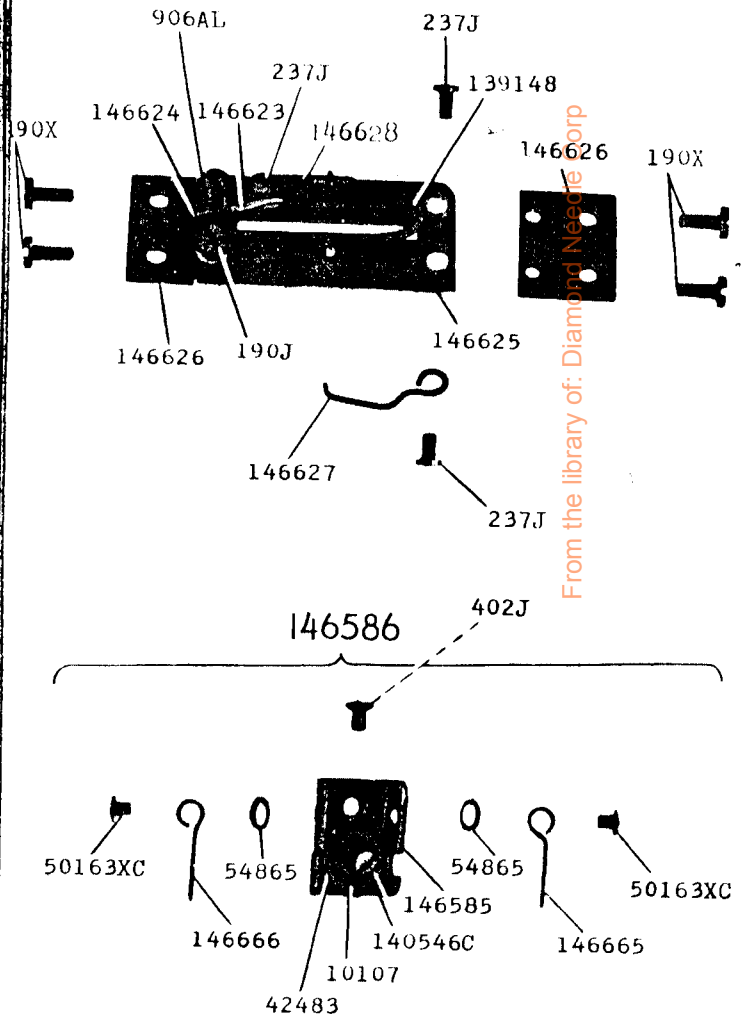
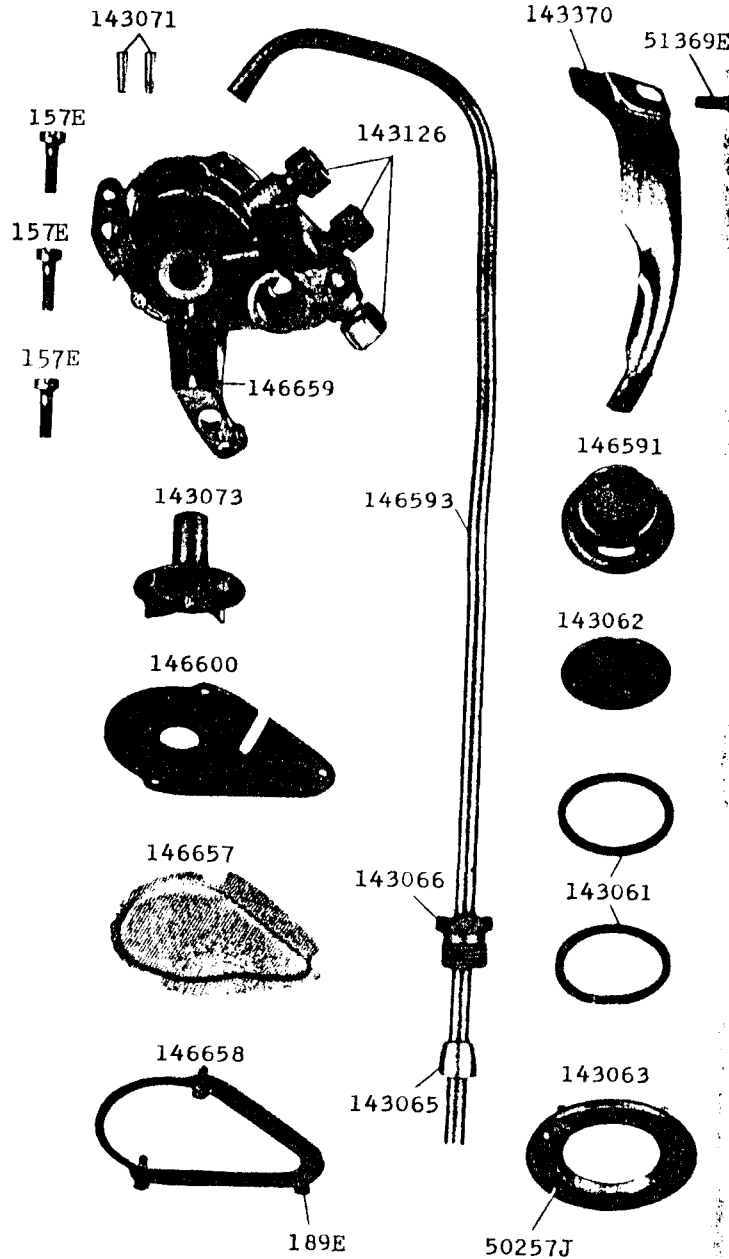

25050-1/2

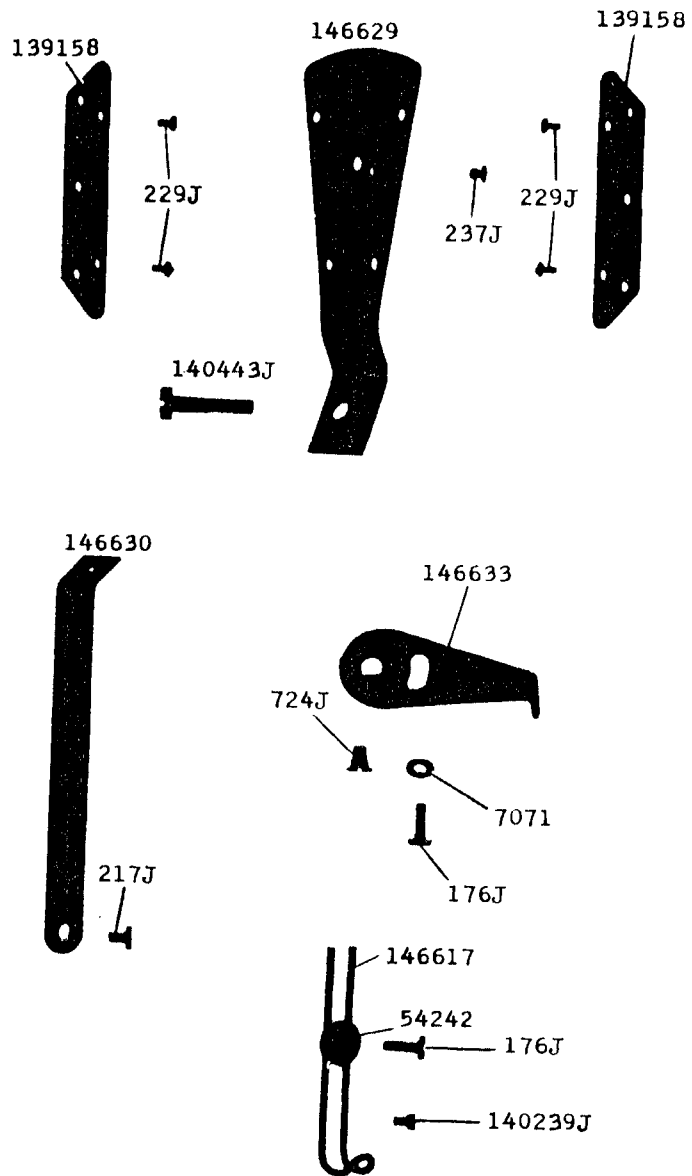

25051-1/2

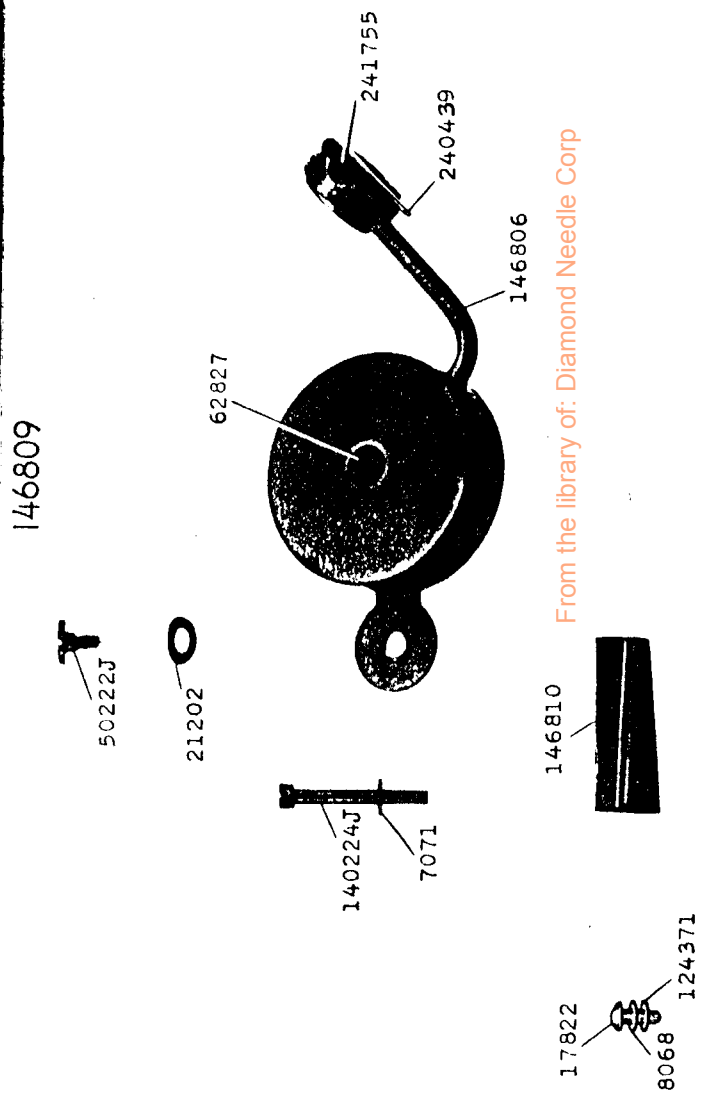

146809

From the library of: Diamond Needle Corp

25072.1/3

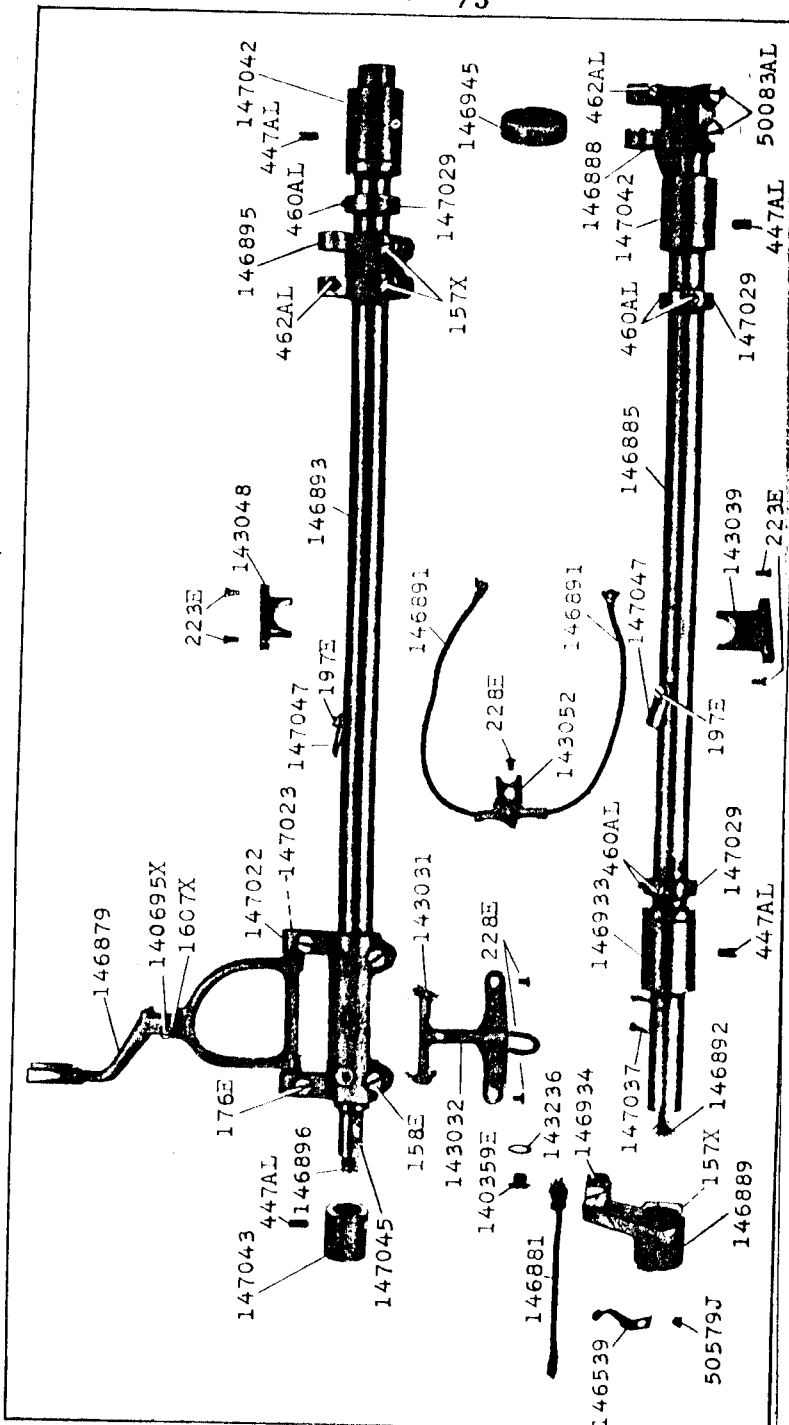

25073.1/3

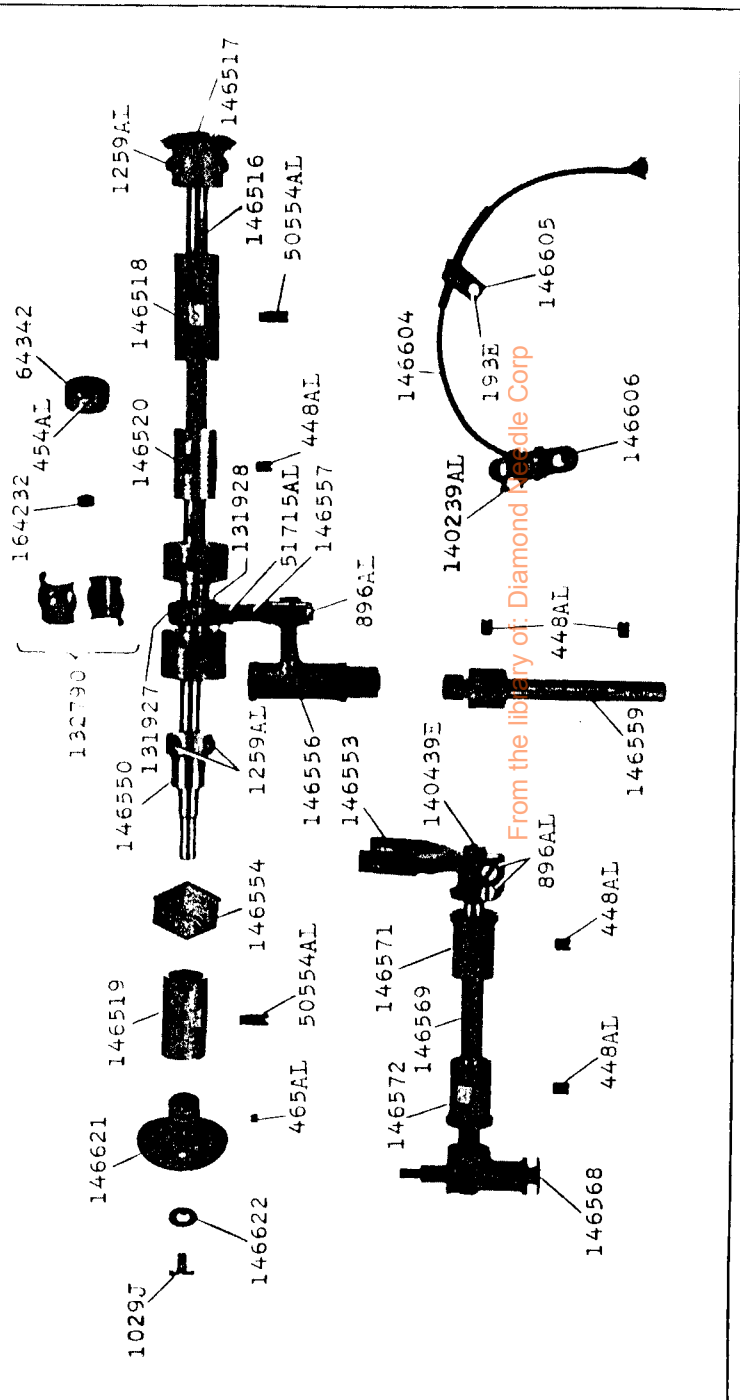

From the library of: Diamond Needle Corp

25074-1/2

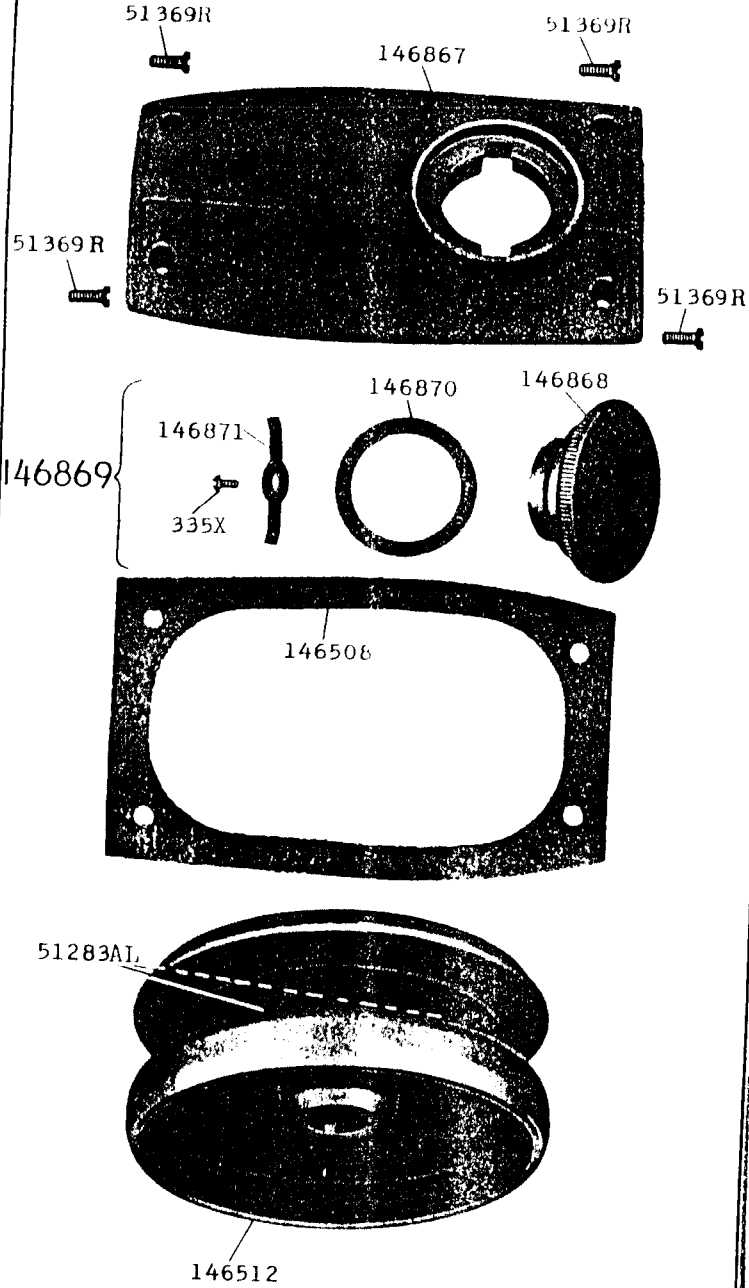

25090-1/2

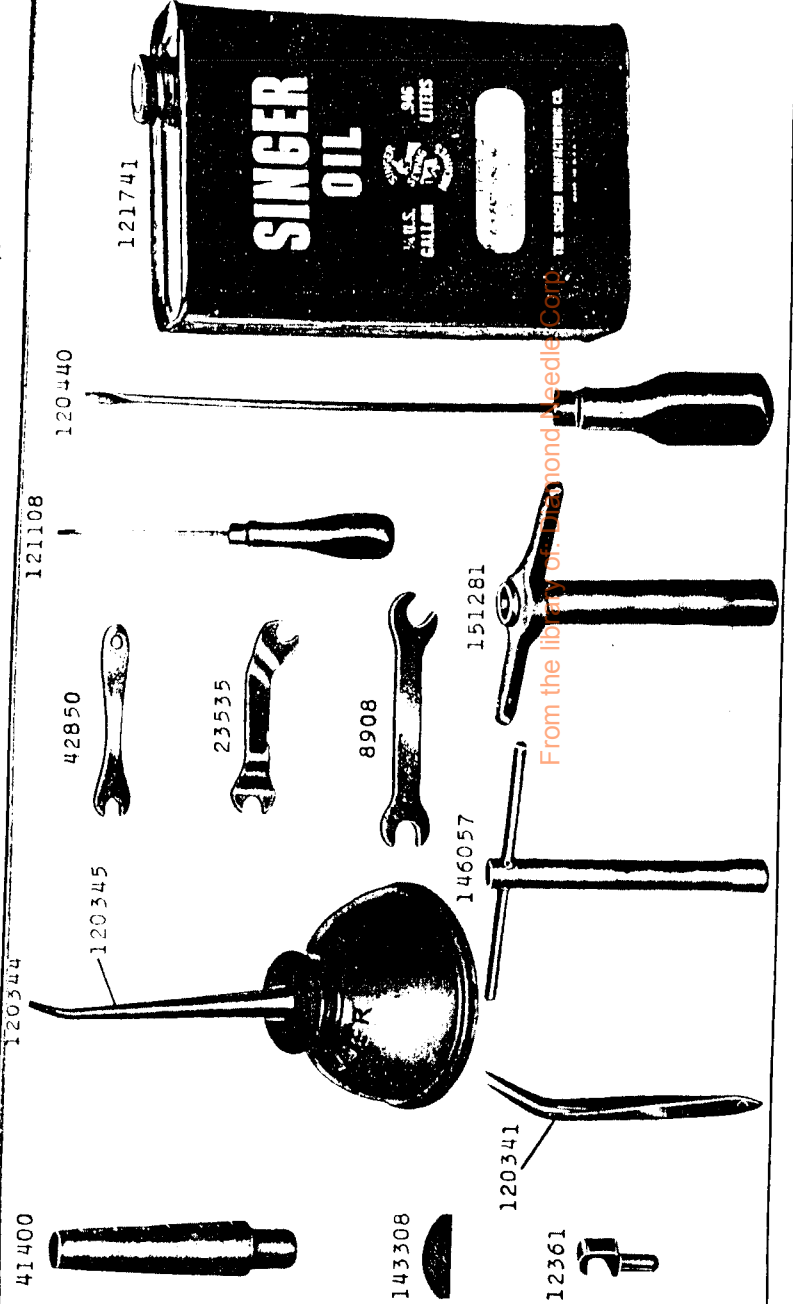

From the library of the University of Toronto

25091-1/3

151367

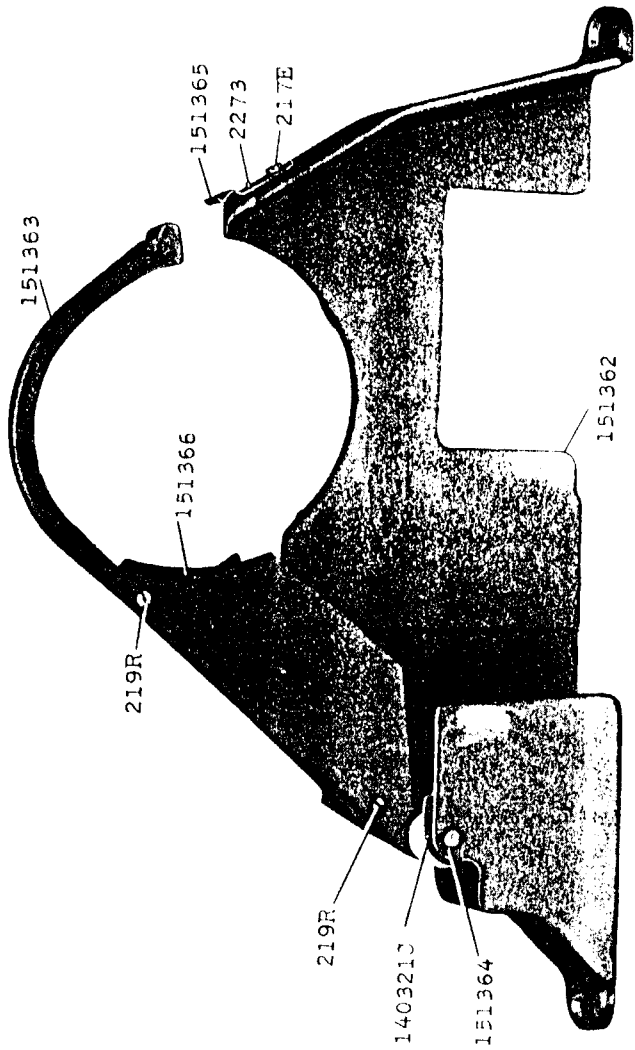

25093-1/3

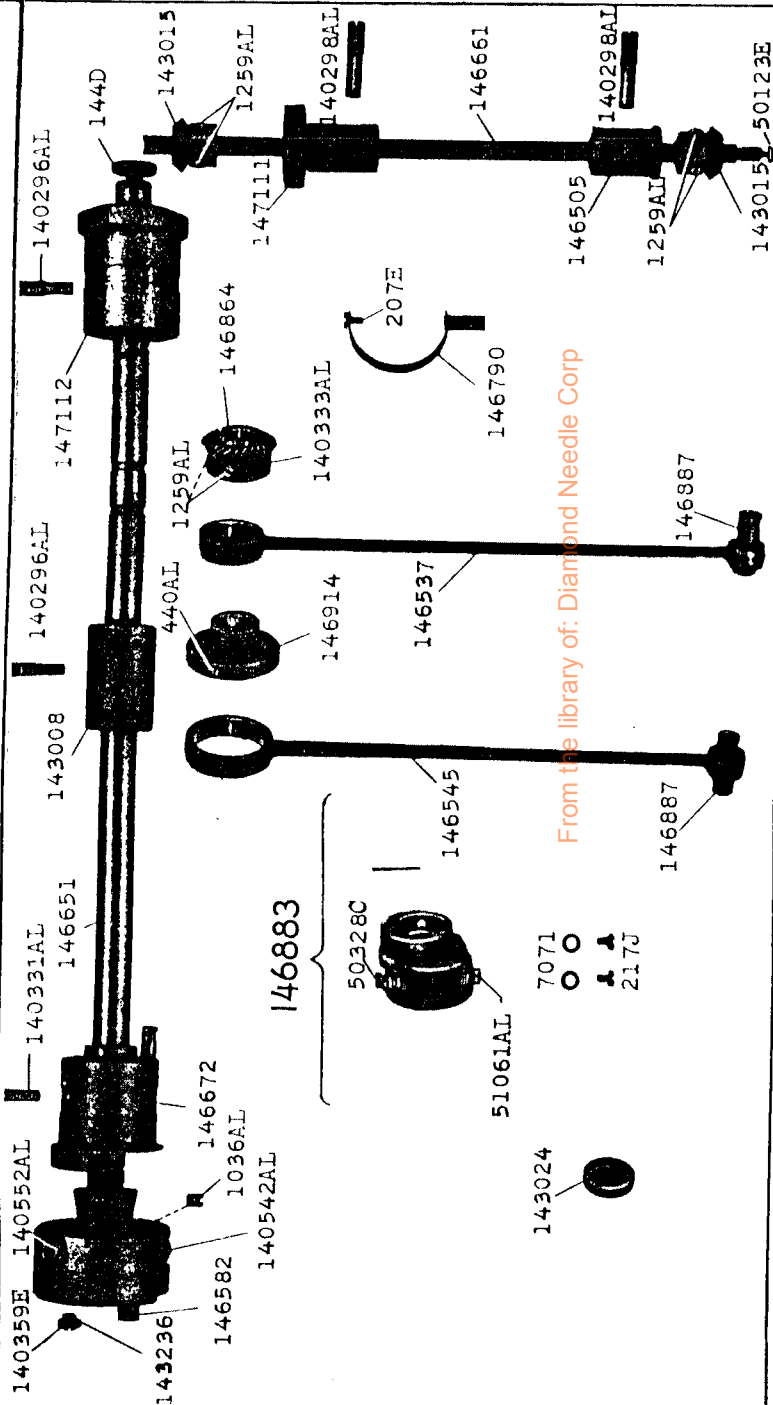

From the library of: Diamond Needle Corp

25094.1/2

146007

146062

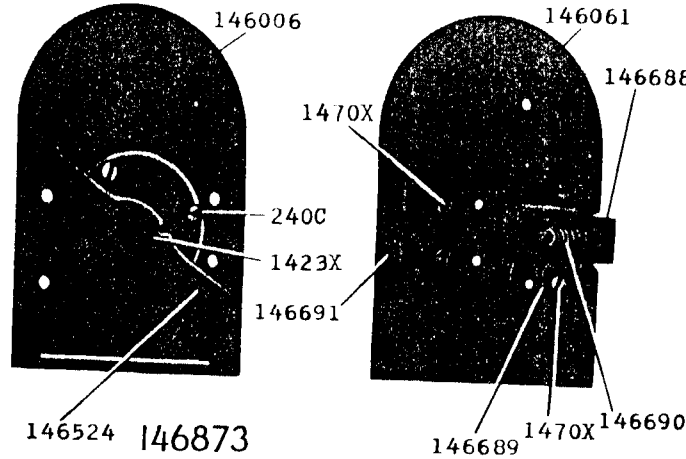

146524 146873

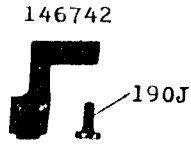
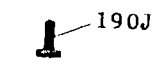
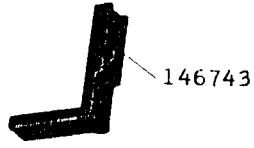
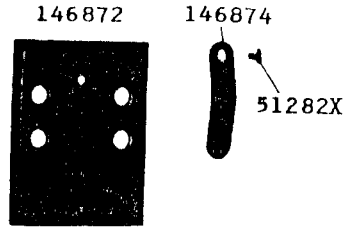

25095.1/2

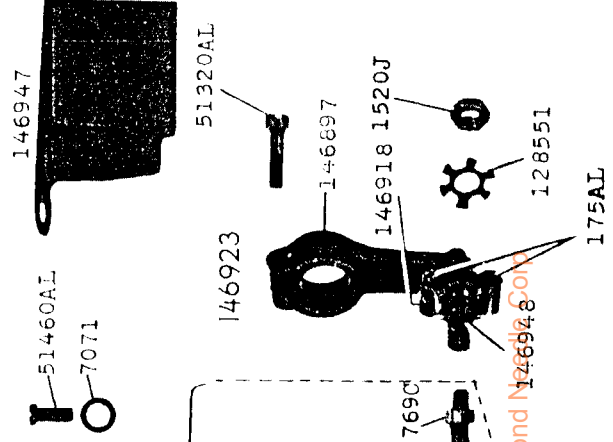

146938

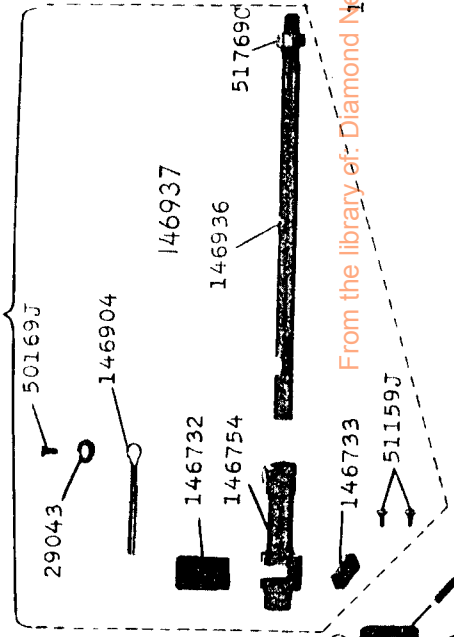

From the library of Diamond 146694 870M

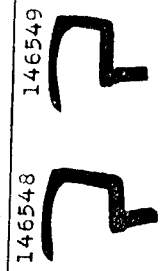

146739

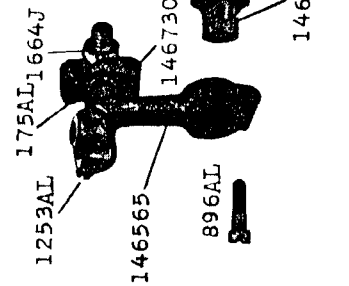



25096-1/2

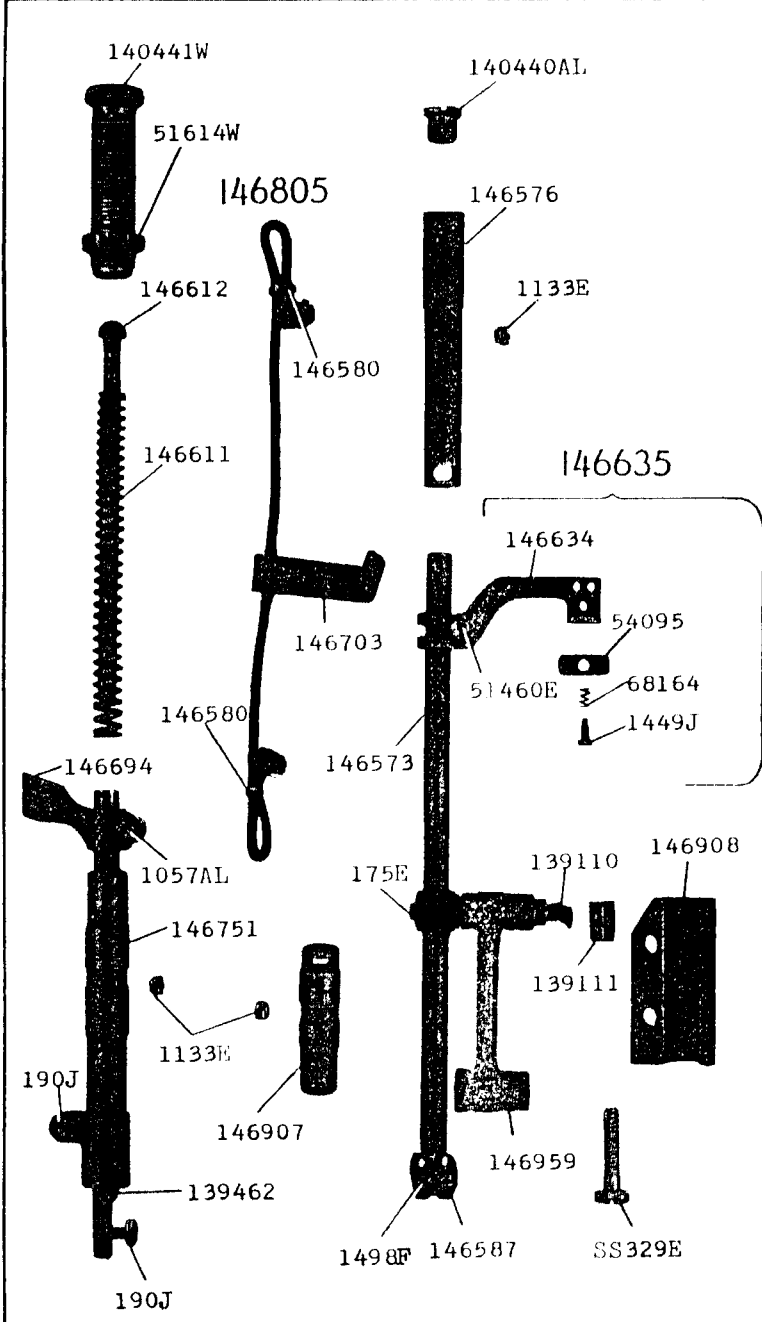

25097-1/2

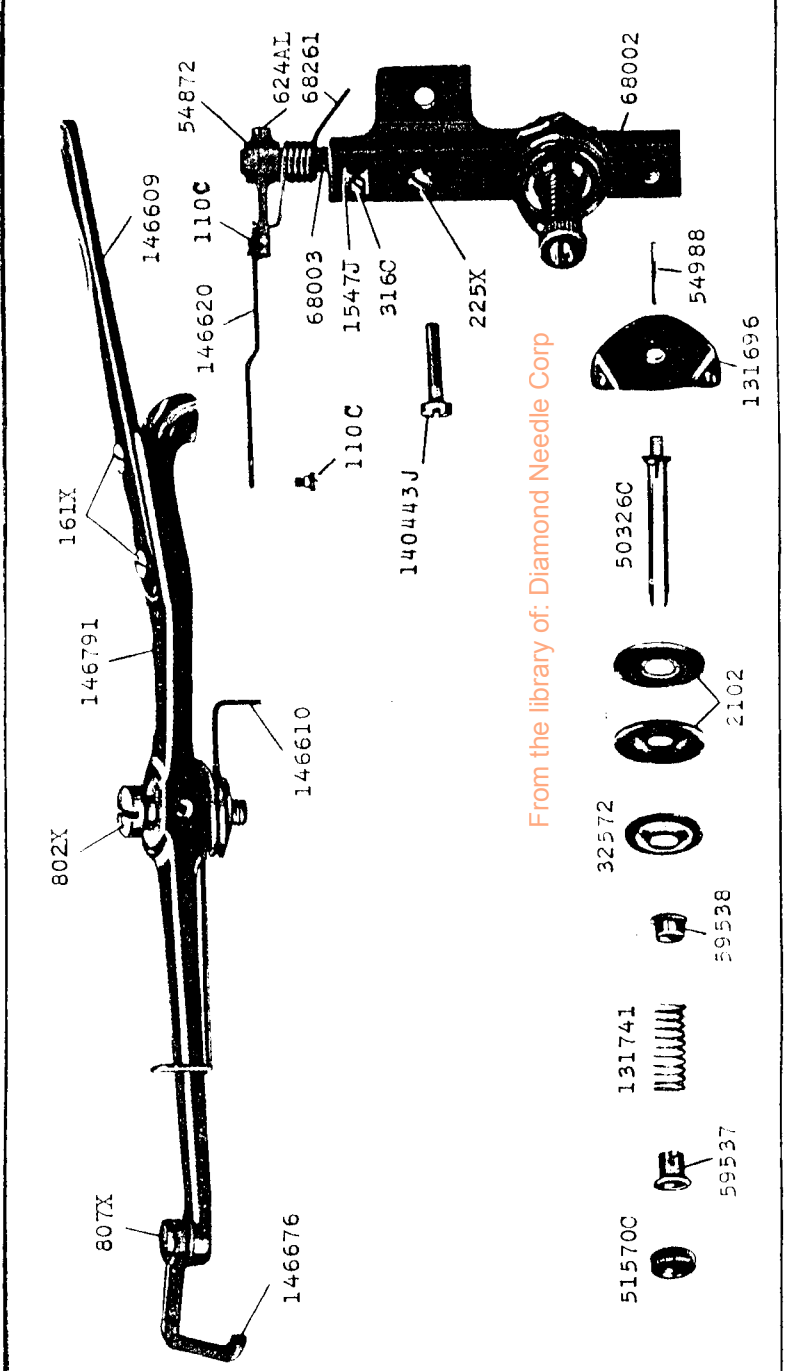

From the library of: Diamond Needle Corp

25098-1/2

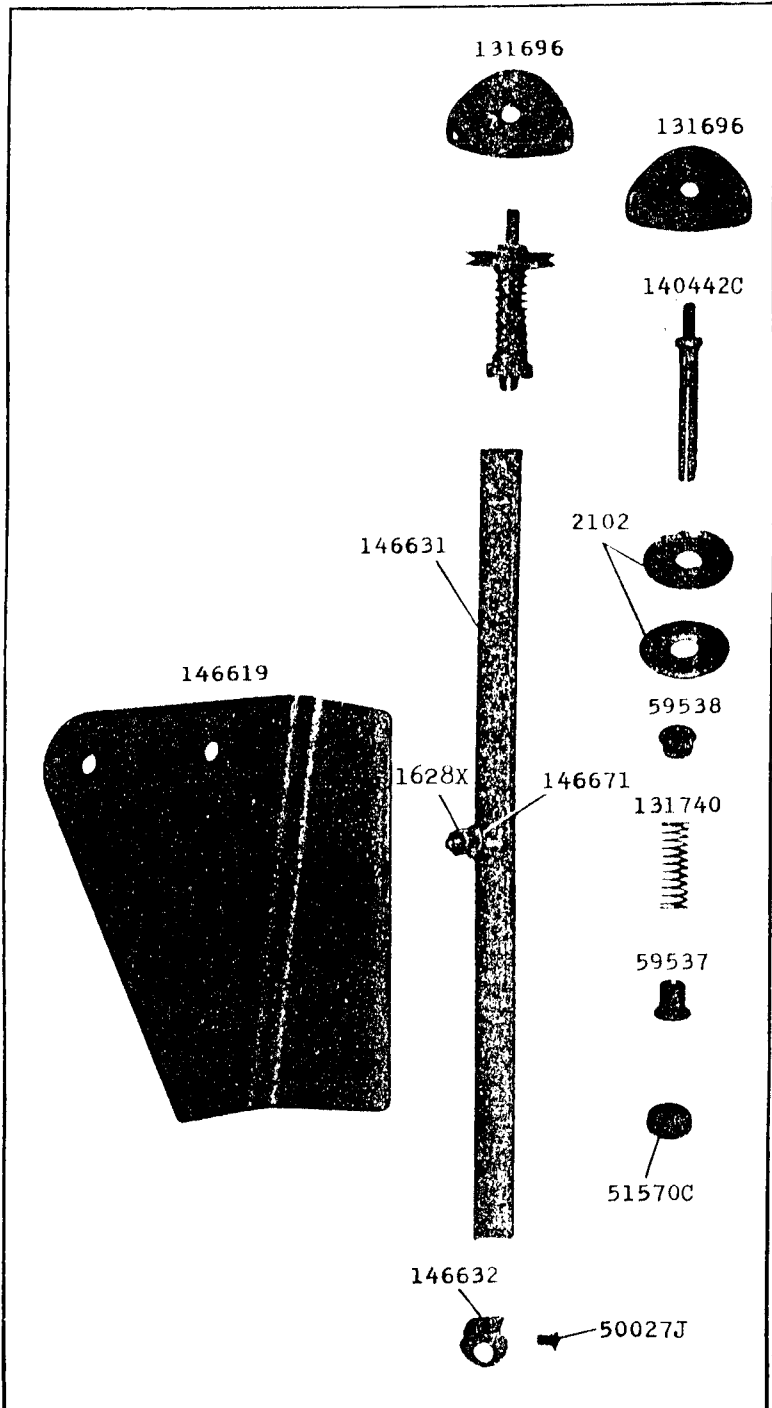

25099-1/2

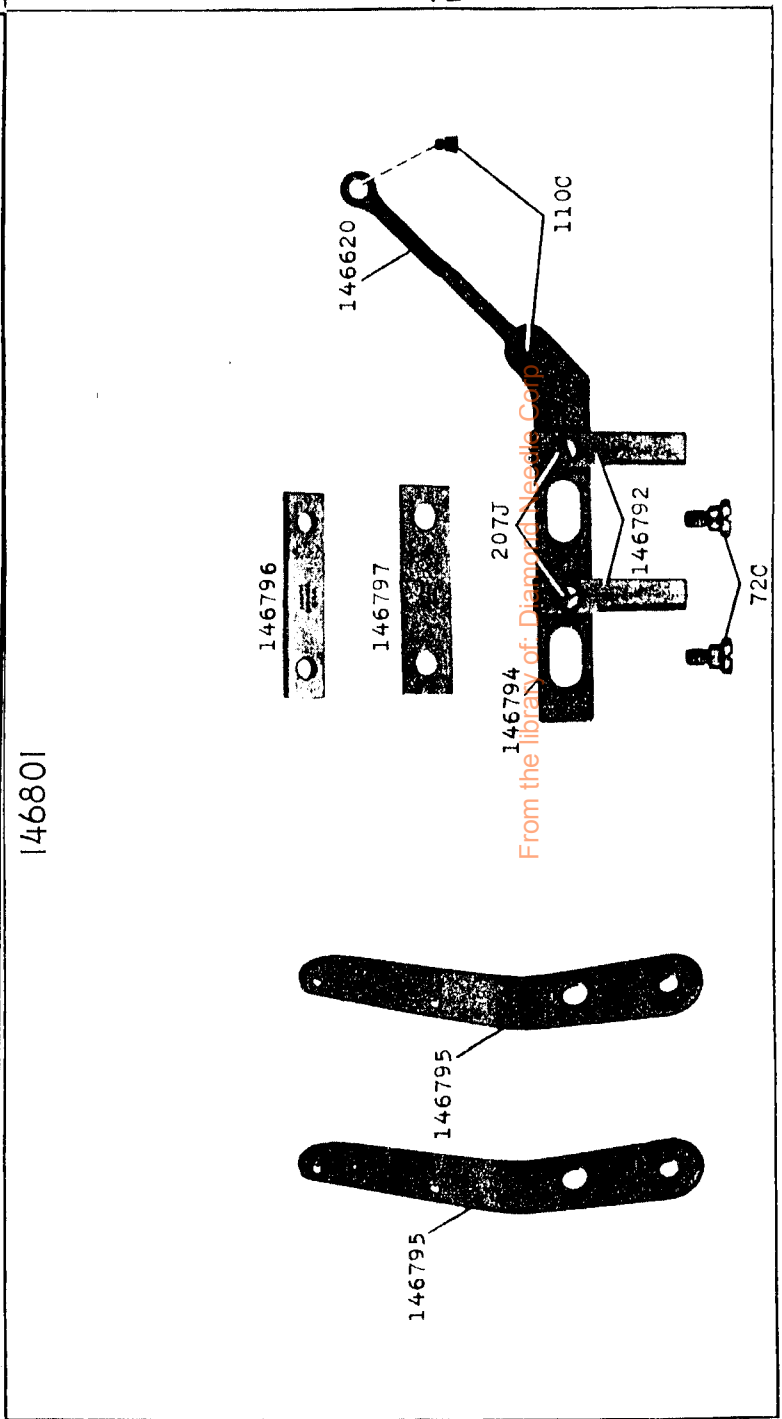

25100-1/2

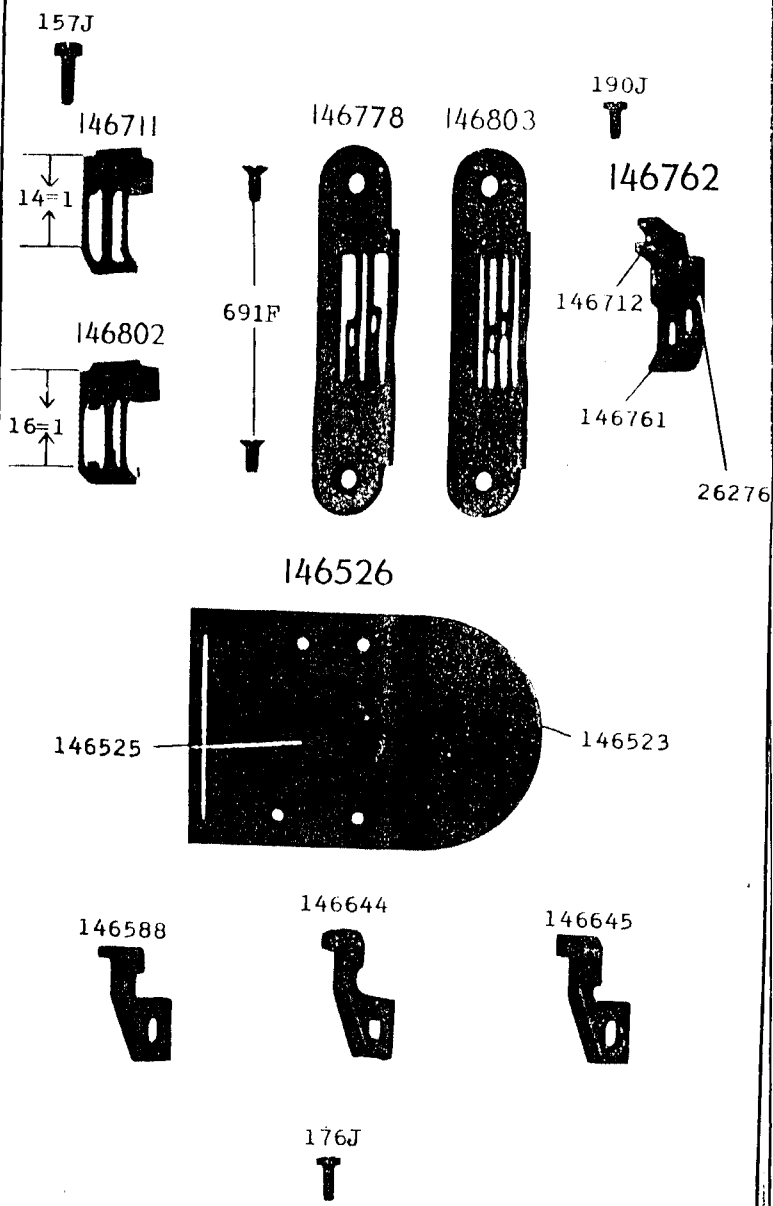

3/32, 1/8, 5/32, 3/16, 7/32, 1/4, 9/32, 5/16, 11/32, 3/8

25101-1/2

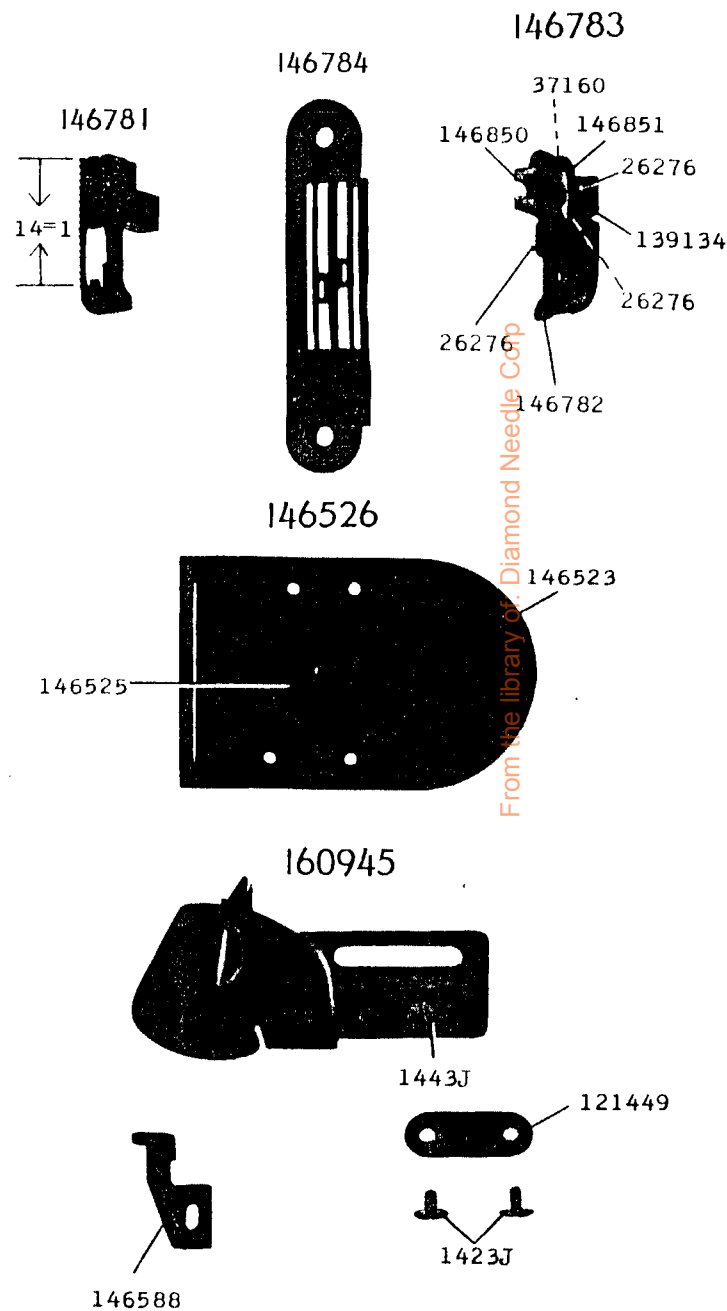

From the library of Diamond Needle Corp

3/32

25102-1/2

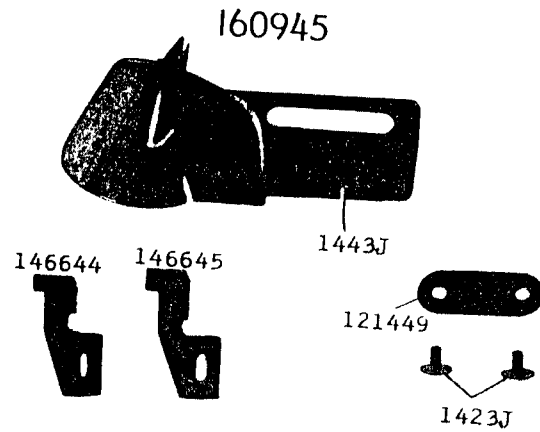
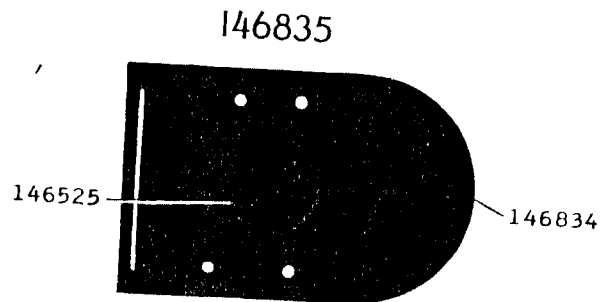
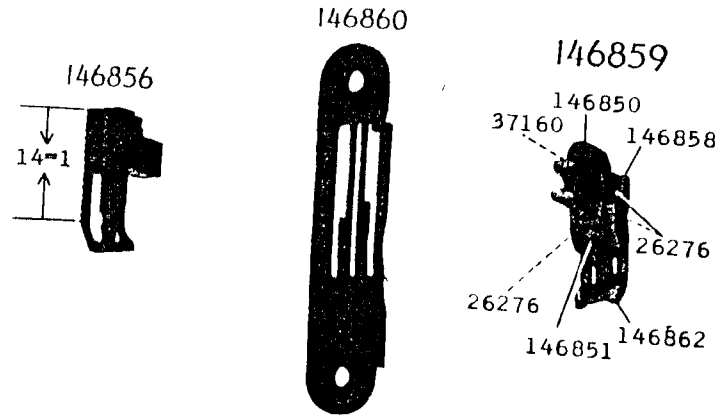

3/16, 7/32, 1/4, 9/32, 5/16, 11/32, 3/8

25103-1/2

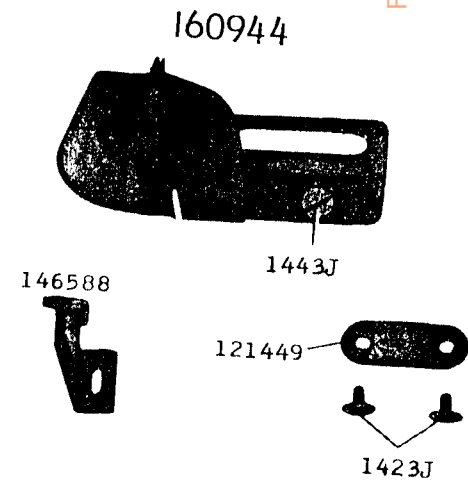
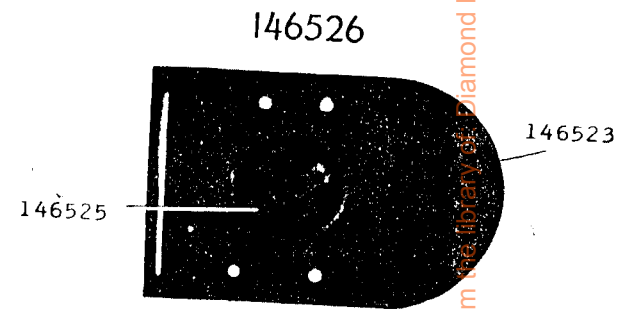
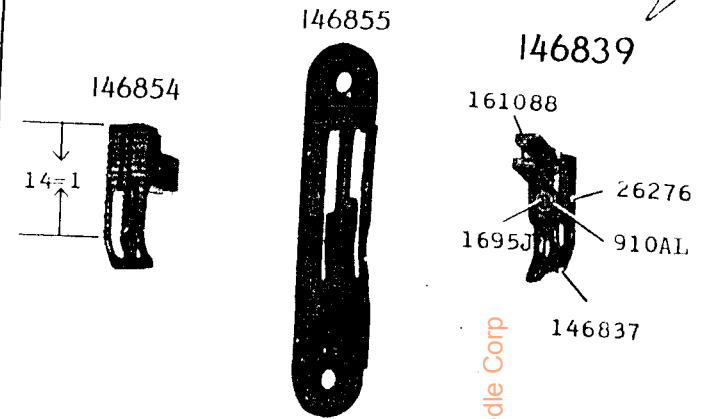

1/8, 5/32

From the library of Diamond Needle Corp

25104-1/2

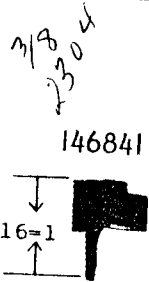

146843

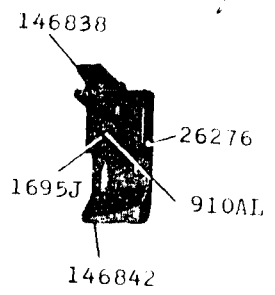

146526

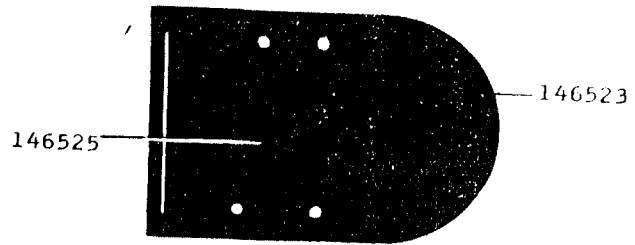

161084

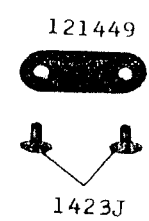
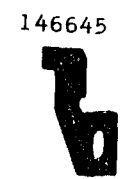
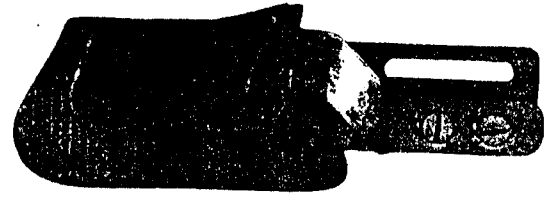

3/8, 13/32, 7/16, 15/32, 1/2

25105-1/2

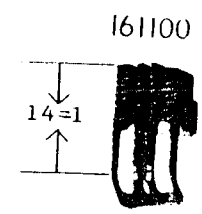

161097

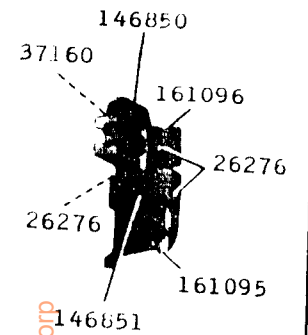

146847

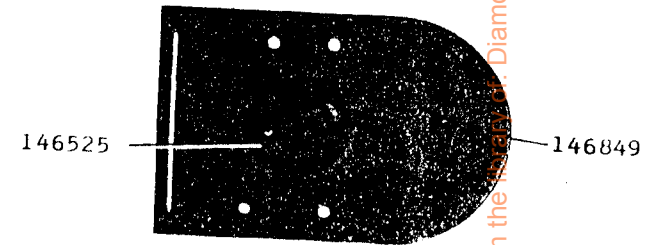

160945

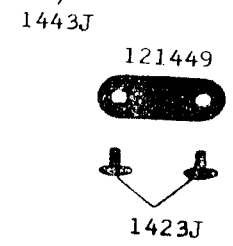
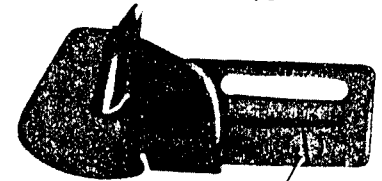

13/32, 7/16, 15/32, 1/2

From the website of Diamond Needle Corp

25106-1/6

151037

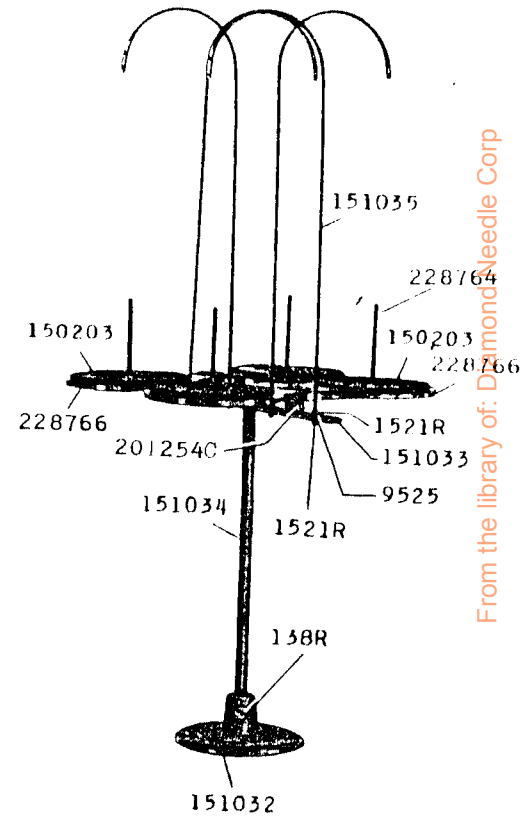

From the library of: Diamond Needle Corp